

PS.PSA SERIES Pressure Switch

(A) Principle

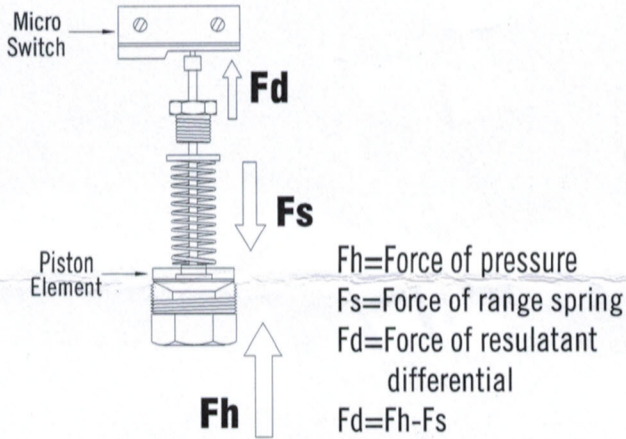

(B) Process installed instruction

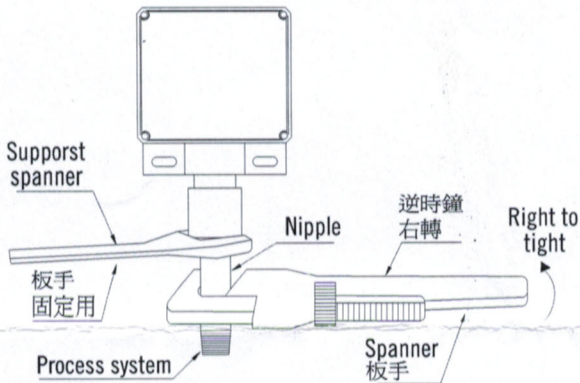

(C) Construction Drawing

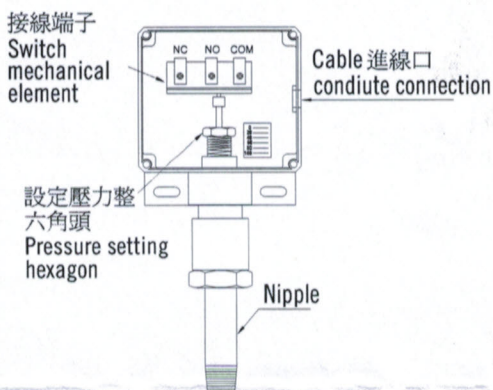

(D) PS Series Range Setting Method

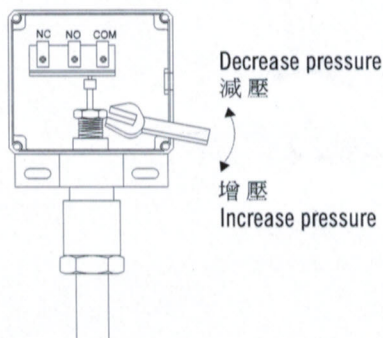

(E) PSA Series Range Setting Method

Pressure setting hexagon is adjusted that is based on E point when ex-factory. To regulate dead band, rotate the gear dial on micro switch then choose the setting for A to F point.

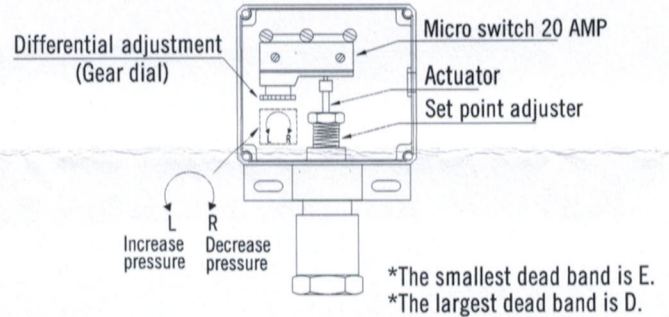

(F) Wire Drawings/Micro Switch Rating

SPDT Wire Drawing (接線圖) DPDT Wire Drawing (接線圖)

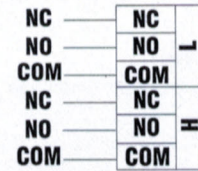
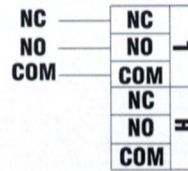

Micro Switch Data:

Switch original maker: HONEYWELL
 Switch data: one SPDT & two SPDT micro switch, 15amps 125/250V, gold contact micro switch 1A 125/250VAC, hermetically sealed switch 3A res. 1A ind. 28V/DC, 1A res. Ind. 115V/AC

(G) Sensitive Repeatability

Skills for set point as follows.

The pressure continues 4 cycles should be operating up to set point, and return to low or high pressure point by request.

Ex.

1. Code 20R-35~200psi, set point 100psi up ON

The pressure operated from "0"psi up to set point 100psi micro switch working at ON. Then return to "0" continued 4 cycles to establish sensitive repeatability.

2. Code 20R-35~200psi, set point 100psi down ON

The pressure operated up to 200psi, then down to 100psi switch working at ON. Then return to 200psi continued 4 cycles to establish sensitive repeatability.