

READ ALL CAUTIONS CAREFULLY BEFORE INSTALLING
PUMP SEE PAGE(3)

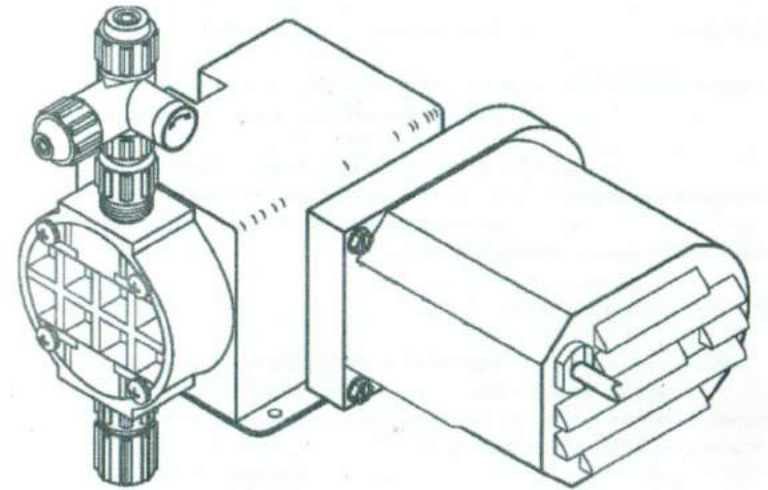

JM SERIES

INSTRUCTION MANUAL



SAFETY INSTRUCTION

READ ALL INSTRUCTION PRIOR TO USE

This appliance is not intended for use by persons (including children) with reduced physical, sensory or mental capabilities, or lack of experience and knowledge, unless they have been given supervision or instruction use of the appliance by a person responsible for their safety.

Secure chemicals & metering pumps, making them inaccessible to children & pets. Make sure children can not touch the pumps.

DO NOT PUMP FLAMMABLE LIQUIDS.

Do not cut the plug or ground plug off the electrical cord. Consult a licensed electrician for proper installation or replacement.

Always wear protective clothing, including gloves and safety glasses when working on or near chemical metering pumps.

Inspect tubing regularly for cracking or deterioration and replace as necessary. **(Always wear protective clothing and safety glasses. when inspecting tubing.)**

Use **CAUTION** to keep fingers away from rotating parts.

If pump is exposed to the direct sunlight, use U.V. resistant tubing.

Follow directions and warnings provided from the chemical manufacturer. The user is responsible for determining the chemical compatibility with the chemical feed pump.

Make sure the voltage on the pump name tag matches the installation voltage. If pump fails to start check line voltage.

Consult with local health officials and/or qualified water conditioning specialists when treating potable water.

Always depressurize system prior to installation or disconnecting the metering pump tubing.

If injection point is lower than the chemical tank and pump, install an anti-siphon valve.

DO NOT MODIFY PUMP. This poses a potentially dangerous situation and will void the warranty.

All pumps are factory tested with water. Remove tubing and thoroughly dry if the chemical being pumped will react with water (for example sulfuric acid).

Hand tighten plastic connections **(Do not use wrench).**

Consult licensed plumber and electrician before installation to conform to local codes.

NOTE: For accurate volume output, pump must be calibrated under all operating conditions.

NOTE: Household and indoor use only

Correct Disposal of this product



This marking indicates that this product should not be disposed with other household wastes through the EU. To prevent possible harm to the environment or human health from.

uncontrolled waste disposal, recycle it responsibly to promote the sustainable re-use of material resources. To return your used device, please use the return and collection systems or contact the retailer where the product was purchased. They can take this product for environmental safe recycling.

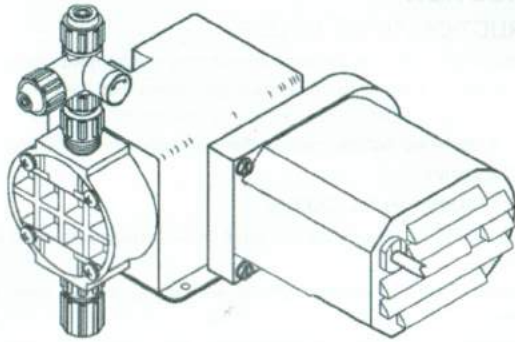

INTRODUCTION

JM series are diaphragm type metering pumps. A fluid is pumped from a chemical storage tank to the point of injection by the pulsing action of the diaphragm. The four check valves (top and bottom of pump head, strainer assembly, and injection assembly) keep the fluid flowing toward to the point of discharge. To insure the solution being pumped can only go forward, it is important that all check valves provide a positive, non-leaking backflow prevention.

The wetted end (those parts that contact the solution being pumped) is constructed of SAN, PVC, TFE, Hypalon, and polyethylene. These materials are very resistant to most chemicals. However, there are some chemicals, such as strong acids or organic solvents, which cause deterioration of some elastomer and plastic parts, such as diaphragm, valve seat, or head. Alternate materials such as Viton, polypropylene and ryton are available on request. Contact chemical supplier for chemical compatible materials.

SPECIFICATIONS

Rated capacity range: 0.47~15.77 L/H
 Max. pressure range: 4.2~7bar
 Strokes/min: 7.13.25.51.70
 Motor: standard 230+/-10% V, 50Hz (IP54)

MANUFACTURER'S PRODUCT WARRANTY

The manufacturer warrants the product to be free of defects in material or workmanship. Liability under this policy extends for one(1) year (don't include spare parts such as diaphragm, valve ball). The manufacturer's liability is limited to repair or replacement of any device or part which is returned, prepaid, to the factory and which is proven defective upon examination. This warranty does not include installation or repair cost.

The manufacturer disclaims all liability for damage to its products through improper installation, maintenance, use or attempts to operate such products beyond their functional capacity, intentionally or otherwise, or any unauthorized repair. Replaceable elastomeric parts are expendable and are not covered by any warranty either expressed or implied. The manufacturer is not responsible for consequential or other damages, injuries or expense incurred through use of its products.

The above warranty is in lieu of any other warranty, either expressed or implied. The manufacturer makes no warranty of fitness or merchantability. No agent of ours is authorized to make any warranty other than the above.

PRECAUTIONS FOR OPERATION

Each pump chemical feeder has been tested to meet prescribed specifications and certain safety standards. However, a few precautionary notes should be adhered to at all times. **THOROUGHLY READ ALL CAUTIONS PRIOR TO INSTALLING METERING PUMP.**

CAUTIONS

- 1 Protective fitting caps must be removed prior to installing tubing onto fitting assemblies.
- 2 Chemicals used may be dangerous and should be used carefully and according to warnings on the label.
 Follow the directions given with each type of chemical. Do not assume chemicals are the same because they look alike. Always store chemicals in a safe location away from children and others. We cannot be responsible for the misuse of chemicals being fed by the pump.
- 3 Always wear protective clothing (protective gloves and safety glasses) when working on or near chemical metering pumps.
- 4 Tampering with electrical devices can be potentially hazardous. Always place chemicals and feeder installation well out of the reach of children and others.
- 5 Be careful to check that the voltage of the installation matches the voltage indicated on the specification label. Each pump is equipped with a three prong plug. Whether plugging into a receptacle or wiring into a system, always be sure the feeder is grounded. If receptacle is utilized, to disconnect, do not pull wire but grip the plug with fingers and pull out.
- 6 Never repair or move the metering pump while operating. Always disconnect electrical current. Before handling the pump always allow sufficient time for the motor housing to cool off. Handling the pump too soon after shutdown may cause hand burns. For safety use protective gloves.
- 7 All pumps are pretested with water before shipment. Remove head and dry thoroughly if you are pumping a material that will react with water, (i.e. sulfuric acid). Valve seats, ball checks, gaskets, and diaphragm should also be dried. Before placing feeder into service, extreme care should be taken to follow this procedure.
- 8 Arrows on the pump head and injection fitting indicate chemical flow. When properly installed, these arrows should be pointing upward.
- 9 When metering hazardous material DO NOT use plastic tubing. Strictly use proper rigid pipe Consult supplier for special adaptors.
- 10 Pump is NOT to be used to handle or meter flammable liquids or materials.
- 11 Standard white polyethylene discharge tubing is not recommended for installations exposed to direct sunlight. Consult supplier for special black polyethylene tubing.
- 12 Manufacturer will not be held responsible for improper installation of pumps, or local plumbing conducted. All cautions are to be read thoroughly prior to hook-up and plumbing. For all installations a professional plumber should be consulted. Always adhere to local plumbing codes and requirements.
- 13 Note the maximum pressure rating of the metering pump. When used with pressurized systems, always be sure the pressure of the system does not exceed maximum pressure rating listed on the specification label.
- 14 Be sure to depressurize system prior to hook-up or disconnection of metering pump.

INSTALLATION, PIPING AND WIRING

UNPACKING, ASSEMBLING AND MOUNTING

The carton should contain:

- Metering Pump
- Clear Flexible Suction Tubing
- Stiff White Discharge Tubing
- Back Check Valve Assembly
- Strainer Assembly w/Tube Weight
- Bleed Valve Assembly
- Instructions

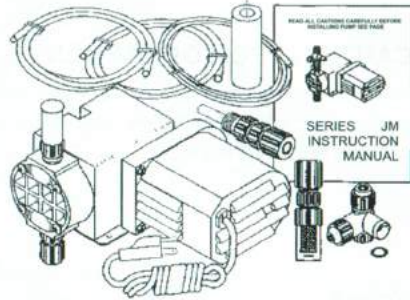

Feeder can be mounted on a wall shelf bracket (Figure B), tank stand platform (Figure C), directly on the wall (Figure D), or directly on the tank cover (Figure E).

IMPORTANT: Injection point must be higher than top of solution tank to prohibit gravity feeding. It is 7Kgt/cm

To mount the feeder directly on the wall, place the feeder base against the wall with the motor below the pumping head, remove four head mounting bolts, and turn head quarter turn so suction is in bottom position.

NOTE: Make sure the arrow on the outside of the pump head is pointing upward. The pump must be positioned so that the plug is accessible.

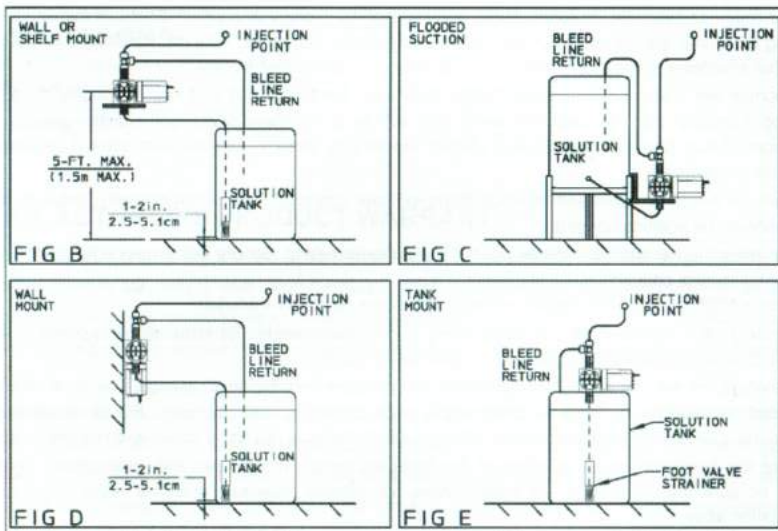

Flooded suction mounting (installing feeder at the base of tank on a platform) is the most trouble free type of installation. (Tank stands and platforms are available for all size feeders and tanks). The pump is secured on the platform, then the clear suction tubing is attached to a bulkhead fitting assembly and the suction valve housing on the pump head. Since the suction tubing is always filled with solution, priming is accomplished much more quickly and the chance of losing prime on an installation, where the feeder is used only a few hours a day, is greatly reduced.

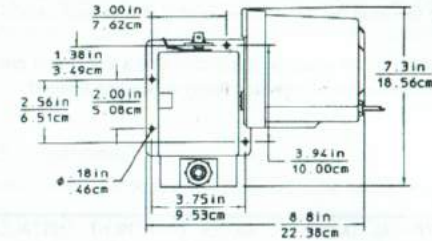

The feeder comes with a bleed valve assembly that attaches to the discharge valve in the pump head. The bleed valve allows you to manually prime the feeder and depressurize the discharge line without disconnecting the feeder from the tubing connections.

NOTE: To operate without bleed valve, replace bleed valve (item #49) and 0.38 in. (0.96 cm) -tubing size discharge valve housing (item #42) with a 0.50 in. (1.27 cm)-tubing size discharge valve housing (item #42) and coupling nut (item #43). See page 16 (Wet End Assembly). items #42 and #43 are available from factory.

NOTE: Do not force fittings Do not use additional sealants, **HAND TIGHTEN ONLY.** such as pipe tape, on fittings.

NOTE: If water is used to dissolve solid chemicals or create a dilute solution, the chemical tanks should be manually filled or an approved means must be used to prevent a cross connection between the chemical tank contents and the potable water line. Check local plumbing regulations.

Chemical injection into an open tank: The discharge tubing can be placed in an open tank with or without the injection valve assembly. Each feeder is shipped with a spring loaded back check injection valve. This assists in a positive seal on the discharge side of the pump head preventing back flow.

Pumps carrying the 'NSF' or the 'ETL Sanitation' (tested to NSF standard-50) approval are listed for swimming pools, spas, and hot tubs, and when proper materials are selected, are capable of handling but not limited to the following chemical solutions. 12% sodium hypochlorite; 2% calcium hypochlorite; 12% aluminum sulfate; 10% hydrochloric acid; 10% sodium hydroxide; 5% sodium carbonate.

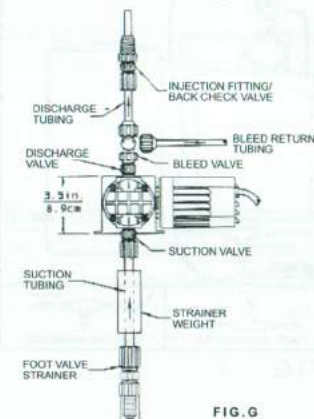

FIG. G

INSTALLATION INTO A WELL PUMP SYSTEM

Make sure the voltage of the feeder matches the voltage of the well pump. Install the injection fitting into a tee which is installed into the water line going to the pressure tank.

The end of the injection check valve should be in the main stream of the water line. A typical installation is shown in Figure H. For installation of pump for operating swimming pools, pump is to be supplied by an isolating transformer or thru an "RCD" (residual current device).

NOTE: It is recommended to install the injection assembly in a vertical position on the bottom side of the water line (Figure J).

This will insure proper sealing of the injection assembly check valve and prevent a back flow into the feeder's discharge line. Be sure arrow on injection fitting is pointing upward.

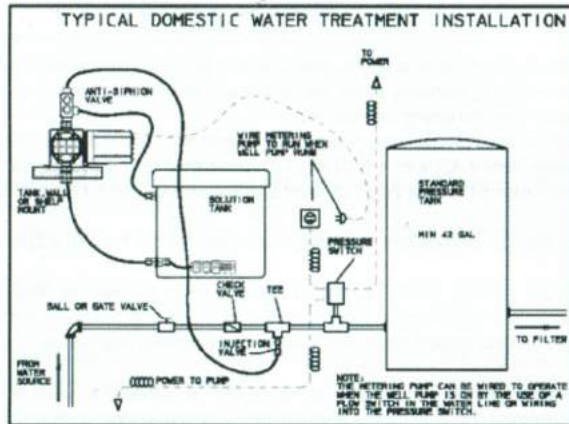

FIG. H

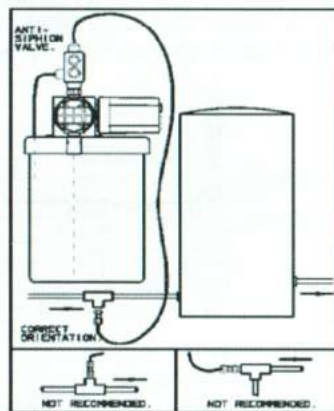

FIG. J

DOWN-THE-WELL INSTALLATION

Often it is desirable to provide chemical feed near the intake of the well pump for additional retention time and mixing of the chemicals. An additional length of discharge tubing will be required for this installation. Secure the end of the discharge tubing to the pump cylinder, drop pipe, or foot valve and lower it into the well.

An anti-siphon valve must be installed on systems such as this where the discharge is lower than the feeder and the chemical storage tank. Failure to install anti-siphon valve may allow siphoning to occur.

ANTI-SIPHON VALVE: (optional)

Under any installation condition where the possibility of siphoning or suction may occur on the discharge side of the pump, install an anti-siphon valve on the discharge side of the feeder. The anti-siphon valve is not part of the standard package. This item can be furnished by your dealer at extra cost.

PRESSURE RELIEF VALVE: (optional)

All JM Series chemical pumps are rated to pump against a line pressure of 100 PSI (7 BAR). If the line pressure on an installation could fluctuate above 100 PSI (7 BAR), install a pressure relief valve on the discharge side of the pump head. Once the pressure reaches a certain level, the preset relief valve will return the solution being pumped back to the solution tank. This will prevent motor burnout or diaphragm rupture. The relief valve is not part of the standard package.

HAND TIGHTEN FITTINGS:

When connecting tubing to suction and discharge fittings, the coupling nuts should be tightened hand tight only. Excessive tightening can cause cracks in pump head.

POINT OF INJECTION:

Pipe corrosion can result if dilution at the injection point does not occur rapidly. This problem is easily prevented by observing this simple rule: install injection fitting so that the end is in the flow stream of the line being treated.

NOTE: Extended injection assemblies are available for large water lines. Consult your dealer.

COMMON ERRORS IN THE INJECTION OF CHEMICALS:

Do not insert the injection fitting into a pipe stub in the tee. A full strength solution will often cause corrosion or scale in the pipe stub when it is not in the flowing stream (Figure J). The maximum lift of the chemical feeder is five feet. Be sure not to exceed this height. It is very important that the arrow on the fittings and the pump head point vertically upward in order to prevent backflow. Arrows indicate the proper flow of the chemical.

POWER

The standard chemical feeder is available in 220V/50HZ single phase. Other volts and 60HZ are available.

NOTE: Be sure the voltage of the feeder matches the power supply. (Figure M)

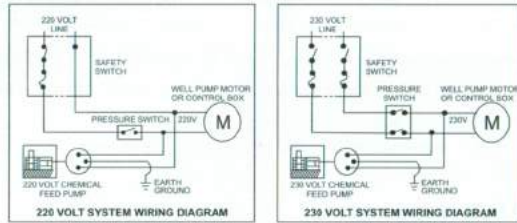

FIG.M

NOTE: All pumps are tested with water. If the chemical to be pumped reacts when mixed with water (e.g. sulfuric acid, polymer) the pump head should be removed and dried thoroughly along with the diaphragm and valve seats.

If the discharge line is connected directly to a pressurized system it should be temporarily bypassed during priming of the pump. This pump is equipped with a bleed valve to simplify this operation by allowing easy bypass of the discharge fluid. All air must be purged from the pump head before the pump will pump against pressure. Turn on the power to the pump. Loosen the locking lever by turning it counter-clockwise and turn the output adjusting knob counter-clockwise to full capacity, (one full turn only) then tighten the locking lever by turning clockwise to a hand tight position. Solution should be primed to the head within a few minutes.

(Refer to Figure K) Air Bleed Operation:

A) While pump is running, turn adjustment screw counterclockwise.

B) Run with valve open until a solid stream of fluid comes out of the bypass tubing (0.25 in (0.63 cm) ID x 0.38 in (0.96 cm) OD) supplied with valve, no air bubbles.

C) Close air bleed valve by turning adjustment screw clockwise.

NOTE: The feeder is adjustable only while running, never force the knob. Do not turn the adjustment knob while the pump is stopped. If the solution hasn't reached the head in a few minutes, disconnect power to the pump, make sure the system is depressurized, remove the discharge tubing and discharge fitting and dampen the discharge valve area (ball check and valve seats) with a few drops of solution being fed by the pump. For safety, use protective gloves and safety glasses and a proper container to hold chemical. Replace the fitting and tubing and restart the pump. Turn the power on once more and adjust the pump to the proper rate, using the locking lever as before.

NOTE: Check calibration of the pump before leaving the installation site. A test for chemical residual in the treated water is the best indication of the correct pump setting.

NOTE: When working on or around a metering pump installation, protective gloves and safety glasses should be worn at all times.

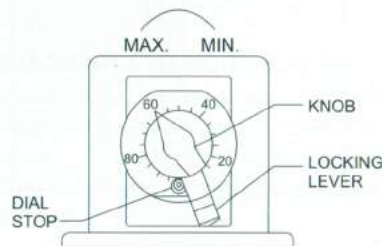

Fig.K

MAINTENANCE

SCALE: GASKETS AND CHECK VALVES

When checking the metering pump or providing routine maintenance, replace all valve seats or ball checks if any of them show any wear or deterioration. (Valve seats should be checked approximately every 4-6 months depending upon the application.) Repeated deterioration of valve seats and other rubber or plastic parts within a few months period usually indicates another material should be used for the defective part. Contact your supplier or see the parts list for parts affected for possible alternate materials.

OUTSIDE INSTALLATION:

In many areas where freezing conditions are not a problem it is common to install a metering pump outside. Adequate protection should be provided to keep the pump from being exposed to direct sunlight or rain. Any simple covering adequately ventilated will afford the necessary protection from weather.

NOTE: When discharge tubing is exposed to direct sunlight, black polyethylene tubing should be used in lieu of the stiff white translucent tubing supplied with each pump.

SOLUTION TANK:

Check the solution tank for settling of chemicals. If there is sludge on the bottom of the solution tank, clean the strainer, the foot valve, and the solution tank. Installing the foot valve a few inches above the bottom of the tank will prevent future clogging.

NOTE: If the chemical being pumped regularly precipitates out of solution or does not dissolve easily or completely (calcium hydroxide), mixers are readily available in different motor configurations and mountings.

OUTPUT ADJUSTING KNOB:

Sometimes the output adjusting knob can move in its shaft and cause a false output indication. This can happen if the knob set-screw slips or if the unit is disassembled for any reason. The unit can be reset to "0" as follows:

- 1 Remove the dial stop.
- 2 With the pump running, loosen the locking lever and turn the adjusting knob counter-clockwise until it is "loose" to touch.
- 3 SLOWLY rescrew the knob clockwise, using very light finger pressure. It will soon start to advance in pulses as the internal cam comes in and out of contact.
- 4 When light finger pressure will no longer allow movement of the knob between cam contacts, grasp the knob securely and tighten the locking lever (turning clockwise) making sure that the knob does not move. To check for zero point, turn on pump. There should be no liquid coming out of discharge fitting.
- 5 Replace dial stop.
- 6 If the pointer is not at "0", loosen the set-screw on the knob (use a .078 in Hex key), and turn pointer to "0", then retighten the set-screw while holding the knob in place.
- 7 A setting of "0" will now give zero output. One full revolution of the knob counter clockwise will give maximum output. The knob should never be turned more than one full revolution.

SERVICING AND REPAIRS

REPLACEMENT OF PUMP HEAD ASSEMBLY OR DIAPHRAGM:

NOTE: Before performing any repairs on JM chemical feeders, be sure to disconnect all electrical connections and relieve pressure from suction/discharge tubing.

The JM feeder was designed so that servicing can be quick and simple. Proper part replacement procedures are described below.

NOTE: Use protective gloves and safety glasses when working on or around chemical feeder.

- 1 Disconnect the tubing. Remove the suction valve and discharge valve being careful not to lose the ball checks and any other small parts. (Figure N)
- 2 Remove the four screws from the face of the head and remove the head.
- 3 Remove the diaphragm by inserting one or two of the head bolts into the holes of the diaphragm and turning counter-clockwise. (Figure O)
- 4 A new pump head or diaphragm should be installed if either is broken or cracked (see parts list at the end of this manual). The new pump head can be installed by going through the above steps in reverse.
- 5 Be sure the drive bracket assembly is in the fully retracted position when installing the new diaphragm. install the new diaphragm by screwing it in hand tight, then back off one-fourth turn or until screw holes are lined up.
- 6 Replace the head and the head screws, being certain the discharge fitting is up **NOTE:** Arrow on outside of pump head should be in vertical position pointing upward. Tighten the head screws evenly and carefully to prevent cracking the head.
- 7 Replace the suction and discharge fittings making sure all gaskets and valves are fitted properly. Do not use teflon tape or other sealants. **HAND TIGHTEN ONLY.** Restart the system as in the start up procedures (INSTALLATION).

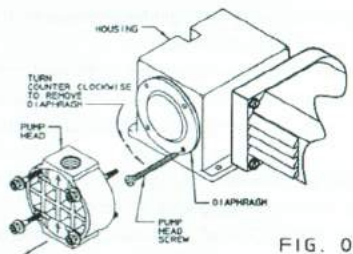
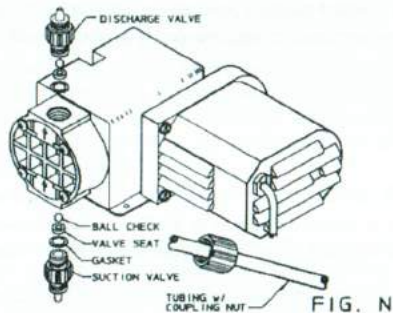

BALL CHECKS AND VALVE SEAT REPLACEMENT:

The following procedure is the same for any of the four valves.

NOTE: Make sure all electrical connections are disconnected and pressure valves off.

NOTE: Use protective gloves and safety glasses while replacing parts.

- 1 Unscrew compression nut and remove tubing.
- 2 Unscrew check valve body from pump head, foot valve, or injection fitting.
- 3 Remove all seats, ball checks, and gaskets and replace.
- 4 Replace the check valve body so fitting makes contact with the gasket and the pump head, foot valve or injection fitting, whichever the case may be. **HAND TIGHTEN FITTINGS ONLY.** Do not use pipe tape or other sealants on these threads.
- 5 Re-install the tubing and tighten coupling nut **HAND TIGHT.**
- 6 Restart the system as in the **INSTALLATION PROCEDURES.**

TROUBLESHOOTING

PROBLEM	PROBABLE CAUSE	REMEDY
LOSS OF CHEMICAL RESIDUAL	<ol style="list-style-type: none"> 1. Pump setting too low 2. Scale at injection point 3. Solution container allowed to run dry 	<ol style="list-style-type: none"> 1. Adjust to higher setting (feeder must be operating during the stroke length adjustment). 2. Clean injection parts with 8% muriatic acid or undiluted vinegar. See Maintenance Section. 3. Refill the tank with solution and prime. See StartUp Section.
TOO MUCH CHEMICAL	<ol style="list-style-type: none"> 1. Feeder setting too high 2. Chemical in solution tank too rich 3. Siphoning of chemical into well or main line 	<ol style="list-style-type: none"> 1. Lower feeder setting (feeder must be operating to adjust the dial). 2. Dilute chemical solution. NOTE: For chemical that reacts with water, it may be necessary to purchase a more dilute grade of chemical direct from chemical supplier. 3. Test for suction or vacuum at the injection point. If suction exists, install an anti-siphon valve. See Figure G.
LEAKAGE AROUND TUBING CONNECTIONS	<ol style="list-style-type: none"> 1. Worn tube ends 2. Chemical attack 	<ol style="list-style-type: none"> 1. Cut off end of tubing (about 1") and then slip on as before or replace suction valve housing and compression fitting to prevent leakage. 2. Consult your chemical supplier for compatible materials.

TROUBLESHOOTING

PROBLEM	PROBABLE CAUSE	REMEDY
UNIT LOSES PRIME	<ol style="list-style-type: none"> 1. Dirty check valve 2. Ball checks not seating or not sealing properly 3. Solution container allowed to run dry 	<ol style="list-style-type: none"> 1. Remove and replace or clean off any scale or sediment. 2. Check seat and ball checks for chips, clean gently. If deformity or deterioration is noted, replace part with proper material. Chemical crystallization can hold check valves open, therefore the valves must be disassembled and cleaned. Be sure to replace all parts as shown in the Parts Diagram (at the end of the manual). 3. Refill the tank with solution and prime.
FAILURE TO PUMP OR FEED	<ol style="list-style-type: none"> 1. Leak in suction side of pump 2. Valve seats not sealing 3. Low solution level 4. Low solution level 5. Diaphragm ruptured 6. Pump head cracked or broken 7. Pump head contains air or chlorine gas 	<ol style="list-style-type: none"> 1. Examine suction tubing. If worn at the end, cut approximately an inch off and replace or replace valve body and coupling nut. 2. Clean valve seats if dirty or replace with proper material if deterioration is noted. 3. When pumping against pressure, the dial should be set above 40% maximum rated capacity for a reliable feed rate. 4. Solution must be above foot valve. 5. Replace diaphragm as shown in "Service" Section. Check for pressure above 100 PSI (7 BAR) at the injection point. NOTE: Chemical incompatibility with diaphragm material can cause diaphragm rupture and leakage around the pump head. 6. Replace pump head as shown in "Service" Section. Do not use pipe tape or other sealants. Make sure fittings hand tight only. Using pliers or wrench can cause cracking and subsequent leakage. 7. While pump is running, turn bleed valve adjustment screw counter-clockwise until air is purged. Close bleed valve.
LEAKAGE AT FITTING	<ol style="list-style-type: none"> 1. Loose fittings 2. Broken or twisted gasket 3. Chemical attack 	<ol style="list-style-type: none"> 1. All fittings can be hand tightened to prevent leakage. Clean off chemicals which have spilled on feeder. 2. Check gaskets and replace if broken or damaged. 3. Consult your chemical supplier for compatible materials.

TROUBLESHOOTING

PROBLEM	PROBABLE CAUSE	REMEDY
FEEDER WILL NOT PRIME	<ol style="list-style-type: none"> 1. Too much pressure at discharge 2. Check valves not sealing 3. Output dials not set at maximum 	<ol style="list-style-type: none"> 1. Open bleed valve and circulate fluid until all air is purged from pump head assembly. Close bleed valve. 2. Disassemble, loosen, clean and check for deterioration or swelling. Reassemble and wet the valve assembly, then prime. See INSTALLATION Section. 3. Always prime pump with output dial set at maximum rated capacity.
ANTI-SIPHON VALVE MALFUNCTION	<ol style="list-style-type: none"> 1. Scale or particles have plugged diaphragm 2. Ruptured valves 	<ol style="list-style-type: none"> 1. Remove, clean and reassemble, being careful not to wrinkle the diaphragm. Check sequence and position of parts to be sure reassembly is correct. 2. Consult your distributor to replacement.
PUMP MOTOR STALLS	<ol style="list-style-type: none"> 1. Pumping against excessive pressure 2. Low voltage to feeder 	<ol style="list-style-type: none"> 1. Test pressure to determine if it exceeds feeder specifications. If so, consult your distributor. 2. Make sure voltage of power source matches the voltage on the feeder specifications label. If not transformers are available.
MOTOR RUNNING VERY HOT	<ol style="list-style-type: none"> 1. Low voltage. 2. If using a stepdown transformer, it may be undersized for the feeder. 	<ol style="list-style-type: none"> 1. Power supply voltage should match voltage on feeder specification label. 2. Check the transformer to be sure it has at least 100 watts capacity.

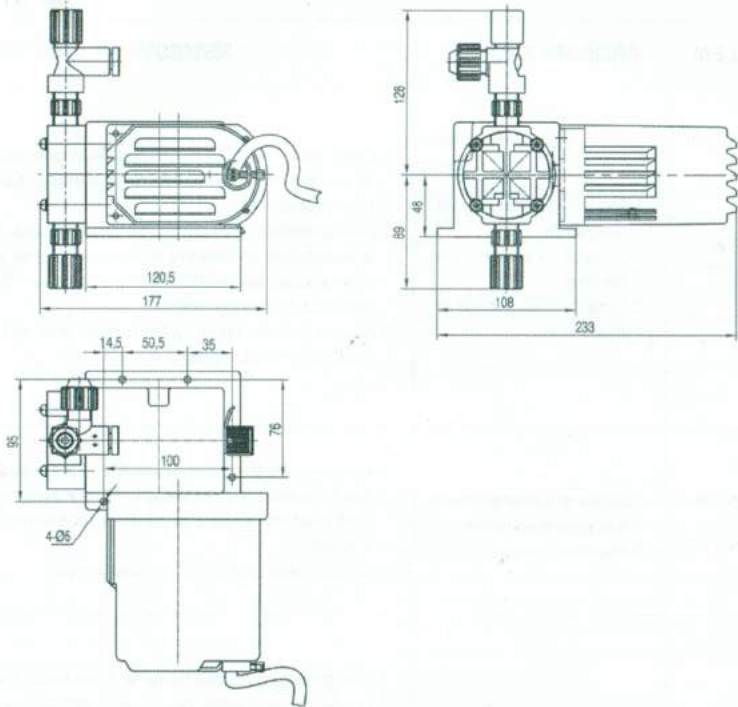

Performance Curve Drawing
Condition: Clean Water

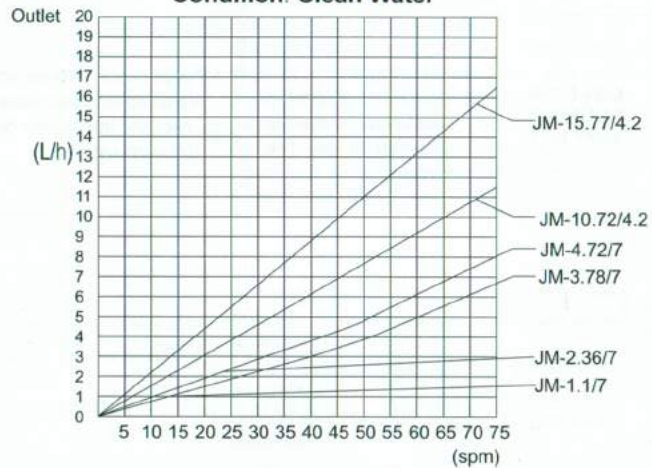

TYPE	STROKE (spm)	CAP.FLOW (L/h)	PRESSURE (Bar)	PLPE SIZE (inch)	POWER (W)	VOLTAGE (V)
JM-0.47/7	7	0.47	7	3/8" (φ 6.5× φ 9.5)	15	100V, 200V, 50-60Hz Single
JM-1.1/7	13	1.10	7			
JM-2.36/7	25	2.36	7			
JM-3.78/7	51	3.78	7			
JM-4.72/7	51	4.72	7	1/2" (φ 9.5× φ 12.7)		
JM-10.72/4.2	72	10.72	4.2			
JM-15.77/4.2	72	15.77	4.2			

MATERIAL

PUMP HEAD	PVC
DIAPHRAGM	1)PTFE+Vition 2)Vition
SUCTION VALVE	ABS
DISCHARGE VALVE	ABS
INJECTION VALVE	ABS
BOTTOM VALVE	ABS/Nylon
BALL VALVE	AL203Ceramics
VALVE SEAT	Vition
"O"-RING	FKM

VOLTAGE PARAMETER

VOLTAGE	AC100V/AC200V(Single)
FREQUENCY	50Hz/60Hz
CURRENT	0.7A
POWER	15W
CABLE	

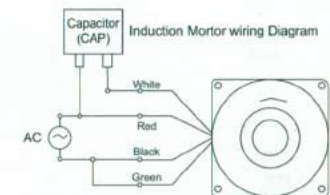

						Installation Drawing, Relative Material and the Performance Curve		JM Series Metering Pump	
								Pump Head Material: PVC	
Mark	Index	Subarea	Changed No	Sign	Date	Phase Mark	QTY		
Design			Standard						
						Total Page		Page of	
Technology						Approval		ZHEJIANG AILIPU PUMP CO.,LTD.	

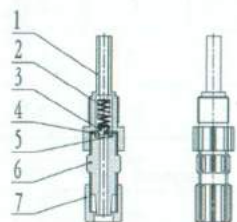
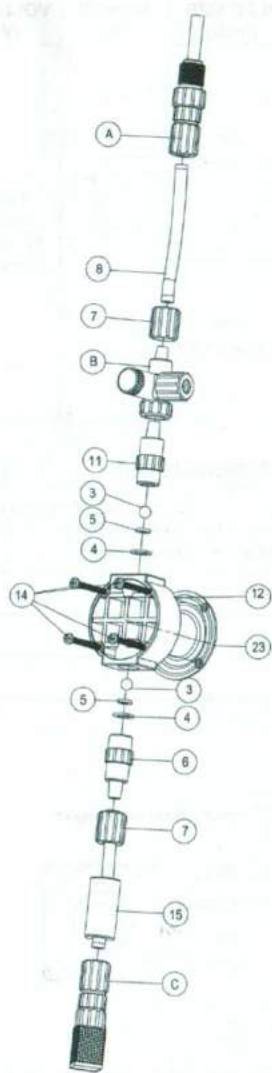

INJECTION VALVE

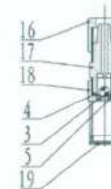

BOTTOM VALVE

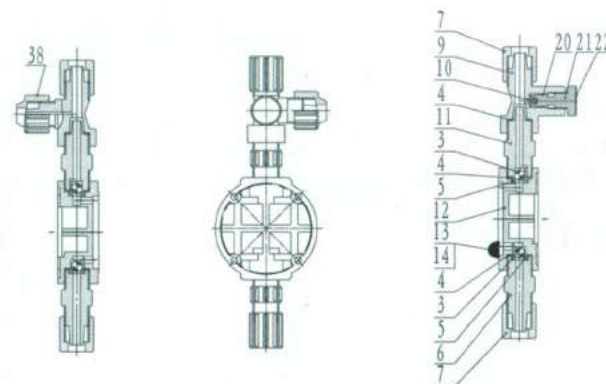
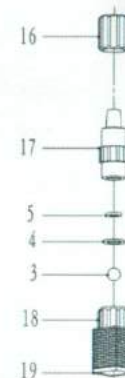

C	JM-00-03	Bottom valve								
B	JM-00-02	Bottom Valve								
A	JM-00-01	Injection Valve								
23	JM-06	Diaphragm	1	Fluorine Rubber+PTFE						
22	JM-26/2	Label	1							
21	JM-26	Valve Pin	1	ABS						
20		O-Ring 8x1.8	1	Fluorine Rubber						
19	JM-30	Filter back Cover	1	ABS/Nylon						
18	JM-29	Filter Body	1	ABS/Nylon						
17	JM-20	Bottom Valve Body	1	ABS/Nylon						
16	JM-11	Bottom Valve Cap	1	ABS/Nylon						
15	JM-32	Tube Weight	1	A12O3Ceramics						
14		Gasket5	4	Stainless Steel						
13		Screw M5 x 50	4	Stainless Steel						
NO.	DRAWING NO.	MAME	QTY	MATERIAL	NO.	DRAWING NO.	MAME	QTY	MATERIAL	
					12	JM-05	Pump Head	1	PVC	
					11	JM-26	Upper Valve Body	1	ABS	Larger than 4.72L/h, with 1/2" pipe
					10	JM-26/1	Bleed Valve End Cap	1	Fluorine Rubber	Larger than 4.72L/h, with 1/2" pipe
					9	JM-25	Three-Function Valve	1	ABS	Larger than 4.72L/h, with 1/2" pipe
					8		Pipe	2	PE	Larger than 4.72L/h, with 1/2" pipe
					7	JM-11	Valve Cap	2	ABS	
					6	JM-12	Valve Body	2	ABS	
					5	JM-07	Valve Seat	4	Fluorine Rubber	
					4	JM-08	Valve Gasket	4	PTEE	
					3		Ball Valve	4	ZrO2Ceramics	
					2	JM-24	Spring	1	Titanium Alloy	NOTE
					1	JM-23	Injection Valve	1	ABS	