

INSTRUCTION MANUAL FOR
TU-2016
TURBIDITY METER



PLEASE READ THIS MANUAL CAREFULLY BEFORE OPERATION

TABLE OF CONTENTS

1. FEATURES.....	1
2. SPECIFICATIONS.....	1
3. FRONT PANEL DESCRIPTION.....	3
3-1 Cover of Testing bottle.....	3
3-2 Container of Testing bottle.....	3
3-3 Display.....	3
3-4 Hold Button (Esc Button).....	3
3-5 TEST/CAL Button.....	3
3-6 Power Button.....	3
3-7 ZERO Button.....	3
3-8 REC Button (MAX, MIN Button).....	3
3-9 Testing bottle with 0 NTU standard solution.....	3
3-10 Testing bottle with 100 NTU standard solution.....	3
3-11 Empty testing bottle 1.....	3
3-12 Empty testing bottle 2.....	3
3-13 Battery Compartment/Cover.....	3
3-14 Clean Cloth.....	3
3-15 Clean Solution (Distill Water).....	3
4. MEASURING PROCEDURE.....	4
4-1 Measurement Consideration.....	4
4-2 Measurement.....	5
4-3 Zero.....	6
4-4 Data Hold.....	6
4-5 Data Record (Max., Min. reading).....	6
5. CALIBRATION PROCEDURE.....	7
6. BATTERY REPLACEMENT.....	11

1. FEATURES

- * Designed to meet ISO 7027.
- * NTU (Nephelometric TURBIDITY Unit) measuring unit.
- * Wide and auto measurement range : 0 to 1,000 NTU.
- * High resolution : 0.01 NTU/1 NTU.
- * The unique optics structure, enables the instrument to read low value of TURBIDITY to the high level up to 1,000 NTU.
- * Four operation buttons and two calibration points, easy operation and guarantee the spec. accuracy.
- * Jumbo LCD, easy readout.
- * Microprocessor circuit assures maximum possible accuracy, provides special functions and features.
- * Battery operated for field and on-site testing convenience.
- * Data hold function for freezing the desired value on display.
- * Records Maximum and Minimum readings with Recall.
- * Heavy duty & compact housing with hard carrying case, designed for easy carry out & operation.
- * Auto shut off is available to save battery life.
- * Application : Test municipal water, food and beverage water, or other aqueous solution where fluid clarity is important.

2. SPECIFICATIONS

Circuit	Custom one-chip of microprocessor LSI circuit.
Display	LCD size : 41 mm x 34 mm.
Range	0.00 to 50.00 NTU, 50 to 1,000 NTU * <i>NTU : Nephelometric Turbidity Unit</i> * <i>Auto range</i>

Accuracy	$\pm 5 \% \text{ F.S.}$ or $\pm 0.5 \text{ NTU}$, which ever is greater.	
Light source	LED, 850 nm.	
Detector	Photo diode	
Standard	Meet ISO 7027.	
Response time	Less than 10 seconds.	
Sample volume needed	10 mL.	
Data hold	Freeze the display reading.	
Memory recall	Maximum & Minimum value.	
Display sampling time	Approx. 1 second.	
Power off	Auto shut off saves battery life or manual off by push button.	
Calibration points	0 NTU, 100 NTU.	
Operating temperature and humidity	0 to 50 °C . Less than 85% R.H.	
Power supply	DC 1.5 V battery (UM4, AAA) x 6 PCs, or equivalent.	
Power current	Stand by	Approx. DC 3.5 mA.
	Testing	Approx. DC 36 mA.
Weight	320 g/0.70 LB. @ <i>Battery is included.</i>	
Dimension	155 x 76 x 62 mm (6.1 x 3.0 x 2.4 inch)	
Accessories Included	Instruction manual 1 PC. Testing bottle with 0 NTU standard solution.....1 PC. Testing bottle with 100 NTU standard solution.... 1 PC. Empty testing bottle.....2 PCs Clean cloth..... 1 PC. Clean solution (Distill water).....1 bottle Hard carrying case, CA-08..... 1 PC.	
Optional Accessories	* Testing bottle with 100 NTU standard solution, TU-100NTU * Empty testing bottle, 0601	

3. FRONT PANEL DESCRIPTION

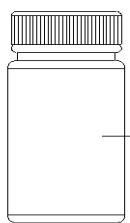
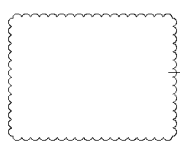
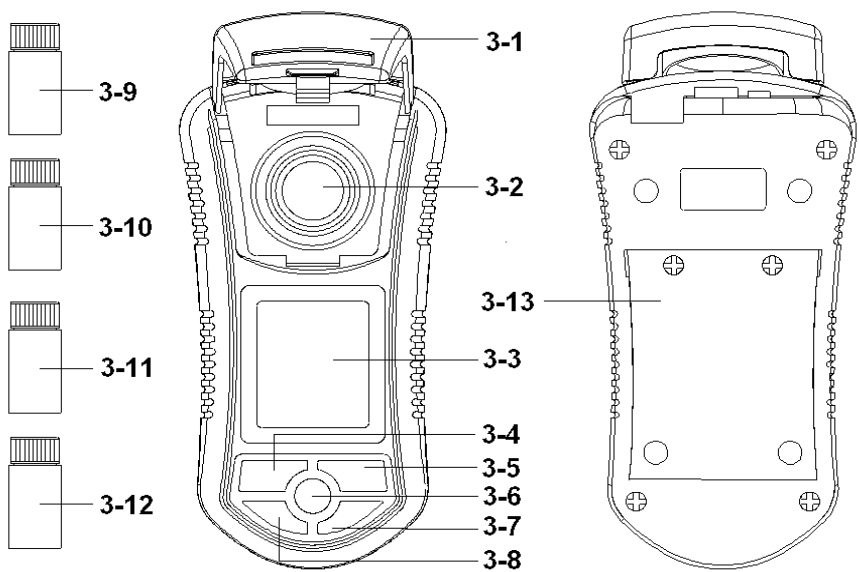

- 3-1 Cover of Testing bottle
- 3-2 Container of Testing bottle
- 3-3 Display
- 3-4 Hold Button (Esc Button)
- 3-5 TEST/CAL Button
- 3-6 Power Button
- 3-7 ZERO Button
- 3-8 REC Button (MAX, MIN Button)
- 3-9 Testing bottle with 0 NTU standard solution
- 3-10 Testing bottle with 100 NTU standard solution
- 3-11 Empty testing bottle 1
- 3-12 Empty testing bottle 2
- 3-13 Battery Compartment/Cover
- 3-14 Clean Cloth
- 3-15 Clean Solution (Distill Water)

4. MEASURING PROCEDURE

4-1 Measurement Consideration

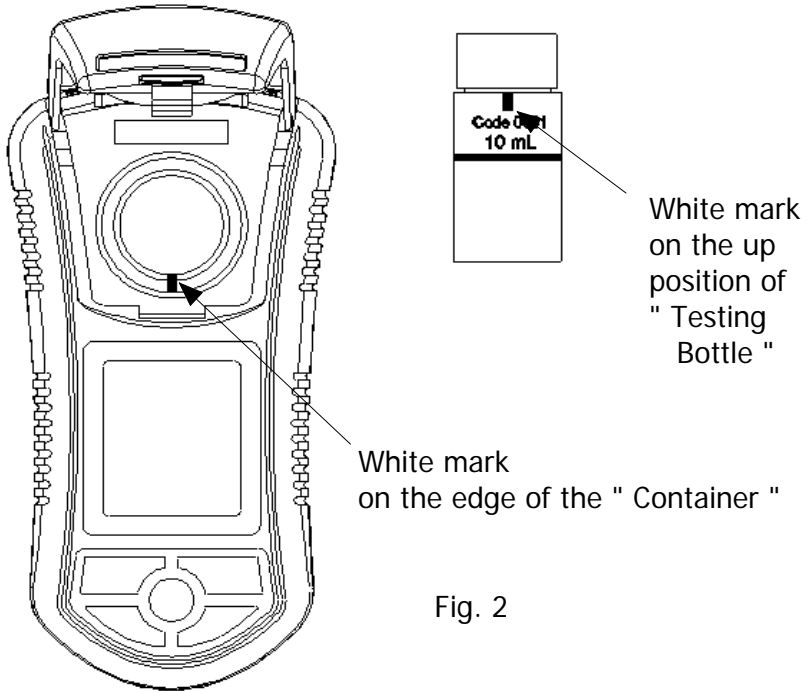

Fig. 2

- 1) There is a " White mark " on the edge of the " Container " (3-2, Fig. 1) and also on the up position of " Testing Bottle " (3-9, 3-10, 3-11, 3-12, Fig. 1), refer Fig. 2.
- 2) When make the measurement (or calibration), it should keep the " Container white mark " face to face together with the " Testing bottle white mark "



- 3) Insert the " Testing bottle " to the bottom of " Container " (3-2, Fig. 1) completely.
- 4) Before the measurement, it should envelop in the " Cover " (3-1, Fig. 1) completely.

Remark :



Before the measurement, it should keep the outside of Testing Bottle under the dry condition and without existing any dust.

4-2 Measurement

- 1) Fill the measurement liquid into the " Testing bottle " (3-11, 3-12, Fig. 1) .

Attention :

It should fill the measurement liquid capacity until its level up to the " level marker " of the " Testing bottle "

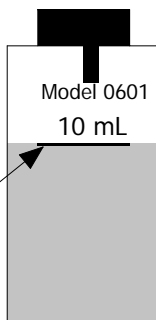

- 2) Insert the " Testing bottle " to the bottom of " Container " (3-2, Fig. 1) completely.
- 3) Before the measurement, it should envelop in the " Cover " (3-1, Fig. 1) completely.
- 4) Power ON the meter by pressing the " Power Button " (3-6, Fig. 1) once.
- 5) Press " TEST Button " (3-5, Fig. 1) once, the display will show the text " tEst " (TEST)", following the " tEst " will flash approx. 10 seconds , then the TURBIDITY value will present on the display along with the " ntu " unit.

Remark :

- * Under power OFF, if press the TEST Button " (3-5, Fig. 1) will power ON and going on to make the test automatically.
- * After the testing, within ten minutes approx., the meter will auto power OFF automatically.



Wash (Reinse) the Testing bottle

- * After the testing, it should wash (reinse) the Testing Bottle by the Clean Solution (Distill Water) " (3-17, Fig. 1).

4-3 Zero

When measure the " 0 NTU " liquid, if the display not show the zero value, it can deduct (offset) those " not zero value " with default, the zero procedures are :

Press the " ZERO Button " (3-7, Fig. 1) continuously until the display show zero value then release the finger from the button

4-4 Data Hold

During the measurement, press the " Hold Button " (3-4, Fig. 1) once will hold the measured value & the LCD will display a " HOLD " symbol.

- * Press the " Hold Button " once again will release the data hold function.

4-5 Data Record (Max., Min. reading)

- * The data record function records the maximum and minimum readings. Press the " REC Button " (3-8, Fig. 1) once to start the Data Record function and there will be a " REC. " symbol on the display.

- * With the " REC. " symbol on the display :
 - a) Press the " REC Button " (3-8, Fig. 1) once, the " REC. MAX. " symbol along with the maximum value will appear on the display.
If intend to delete the maximum value, just press the " Hold Button " (3-4, Fig. 1) once, then the display will show the " REC. " symbol only & execute the memory function continuously.
 - b) Press the " REC Button " (3-8, Fig. 1) again, the " REC. MIN. " symbol along with the minimum value will appear on the display.
If intend to delete the minimum value, just press the " Hold Button " (3-4, Fig. 1) once, then the display will show the " REC. " symbol only & execute the memory function continuously.

5. CALIBRATION PROCEDURE

- 1) The meter can be calibrated under two kinds standard solution :

- 0 NTU standard solution**
 - 100 NTU standard solution**

- 2) The meter ship along with

- a. Testing bottle with 0 NTU standard solution x 1 PC**
 - b. Testing bottle with 100 NTU standard solution x 1 PC**

as the standard accessories.

- 3) The complete calibration should be executed by following two solution :

- 0 NTU standard solution**
 - 100 NTU standard solution**

4) **Shaking the calibration bottle**

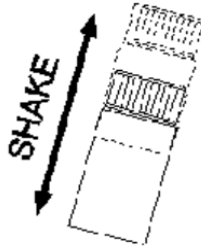

**Before execute the calibration, it should shake the
Standard solution (TU-0NTU, TU-100NTU)
at least 5 seconds to keep the calibration solution
under the uniform condition.**

5) **0 NTU calibration**

- * Insert the " 0 NTU standard solution into the
" Container " (3-2 , Fig. 1) and envelope in the " Cover "
(3-1, Fig. 1) completely, other procedures please
refer to above section 4-1, 4-2.
- * Press " CAL Button " (3-5, Fig. 1) continuously
until the Display show the text " CAL " then release
the button.



- * During the display show text " CAL ", press the " CAL Button " (3-5, Fig. 1), the display will show



Now the meter is ready for the " 0 NTU " calibration

- * Press " CAL Button " (3-5, Fig. 1) once, the Display will show following text with flashing (approx. 10 seconds).



Then the Display will show :



Now the meter is finished the " 0 NTU " calibration procedures and ready for " 100 NTU " calibration procedures.

6) **100 NTU calibration**

Refer to page 8, when finish the " 0 NTU " calibration procedures and the Display show



The meter is ready for " 100 NTU " calibration.

- * Insert the " 100 NTU standard solution into the " Container " (3-2 , Fig. 1) and envelope in the " Cover " (3-1, Fig. 1) completely.

Press " CAL Button " (3-5, Fig. 1) once, the Display will show following text with flashing (approx. 10 seconds).



Then the LCD display will return to normal measurement screen, now the meter is finished the calibration procedures (0 NTU, 100 NTU calibration) completely and ready for the measurement.

6. BATTERY REPLACEMENT

- 1) When the left corner of LCD display show " , it is necessary to replace the battery. However, in-spec. measurement may still be made for several hours after low battery indicator appears before the instrument become inaccurate.
- 2) Loss the " Battery Cover Screws " and slide the " Battery Cover " (3-13, Fig. 1) away from the instrument and remove the battery.
- 3) Replace with DC 1.5 V battery (UM4, AAA, Alkaline/heavy duty) x 6 PCs, and reinstate the cover.
- 4) Make sure the battery cover is secured after changing the battery.