



User Guide

RTD TRANSMITTER

SM5000-RTD / SM5010-RTD
SM5400-RTD
SM5000-RTM / SM5010-RTM
SM5400-RTM

Contents (Index on Next Page)

PREFACE/SAFETY.....	4
1. COMPLIANCES/CONFORMITÉ.....	5
2. CERTIFICATIONS.....	7
3. PRODUCT & SYSTEM OVERVIEW.....	8
4. HARDWARE OVERVIEW.....	9
5. NETWORK DIAGRAM.....	10
6. REQUIRED ITEMS FOR BASIC SETUP.....	11
7. CONFIGURATION/INSTALLATION SEQUENCE.....	12
8. BATTERY PACK INSTALLATION.....	13
9. WIRING DIAGRAM – FOR MULTI-VENDOR TYPE.....	14
10. TRANSMITTER INSTALLATION.....	14
11. GROUNDING BEST PRACTICES.....	16
12. RF SETUP / RF SECURITY.....	18
13. DOWNLOAD & INSTALL BreeZ®.....	20
14. CREATE A PROJECT FILE USING BreeZ®.....	20
15. MANAGING MODBUS MAPPING TABLE.....	26
16. SET UP COM PORT ON PC AND BreeZ®.....	27
17. UPDATING TRANSMITTER.....	29
18. UPGRADING TRANSMITTER FIRMWARE.....	30
19. POLL MODBUS REGISTERS USING BreeZ® & GATEWAY.....	31
20. WIRELESS SITE SECURITY KEY.....	33
21. ERROR CODE TABLE.....	35
22. TROUBLESHOOTING - TRANSMITTER.....	36

23. GENERAL MAINTENANCE.....	39
24. GLOSSARY.....	39
25. ATEX / IECEx INSTRUCTIONS.....	42
26. LIMITED WARRANTY.....	44
27. REVISION HISTORY.....	44

Index	
ATEX / IECEx INSTRUCTIONS	42
BATTERY PACK INSTALLATION	13
CERTIFICATIONS	7
COMPLIANCES/CONFORMITÉ	5
CONFIGURATION/INSTALLATION SEQUENCE	12
CREATE A PROJECT FILE USING BreeZ®	20
DOWNLOAD & INSTALL BreeZ®	20
ERROR CODE TABLE	35
GENERAL MAINTENANCE	39
GLOSSARY	39
GROUNDING BEST PRACTICES	16
HARDWARE OVERVIEW	9
LIMITED WARRANTY	44
MANAGING MODBUS MAPPING TABLE	26
NETWORK DIAGRAM	10
POLL MODBUS REGISTERS USING BreeZ® & GATEWAY	31
PREFACE/SAFETY	4
PRODUCT & SYSTEM OVERVIEW	8
REQUIRED ITEMS FOR BASIC SETUP	11
REVISION HISTORY	44
RF SETUP / RF SECURITY	18
SET UP COM PORT ON PC AND BreeZ®	27
TRANSMITTER INSTALLATION	14
TROUBLESHOOTING - TRANSMITTER	36
UPDATING TRANSMITTER	29
UPGRADING TRANSMITTER FIRMWARE	30
WIRELESS SITE SECURITY KEY	33
WIRING DIAGRAM – FOR MULTI-VENDOR TYPE	14

PREFACE/SAFETY

Thank you for choosing the RTD Transmitter by OleumTech®.

This document describes the hardware components and how to create a basic setup of a Wireless System. This document also describes how to maintain and troubleshoot the device.

 **WARNING:** Ensure installation of the Transmitter meets applicable state and national electrical code requirements. The installation of the Transmitter should only be performed by a qualified installer or a factory representative.

 **AVERTISSEMENT:** Veiller à l'installation de la passerelle répond Etat et des exigences nationales de code de l'électricité. L'installation de la DH3 ne doit être effectuée par un installateur qualifié ou un représentant de l'usine.

 **WARNING:** Replacement battery MUST ONLY be the 3.6 Volt Lithium Battery Pack, SX1000-BP3, supplied by OleumTech. Use of any other battery or battery packs may negatively affect device performance, void device warranty, and may result in an explosion.

 **AVERTISSEMENT:** Batterie de remplacement ne doit être la Volt Lithium Battery Pack 3.6, SX1000 - BP3, fourni par OleumTech. L'utilisation d'autres batteries ou batterie peut affecter négativement les performances de l'appareil, la garantie de l'appareil vide, et peut entraîner une explosion.

 **WARNING:** To prevent static discharge, wipe with damp cloth only.

 **AVERTISSEMENT:** Pour éviter une décharge statique, essuyer avec un chiffon humide.

 **WARNING:** To prevent ignition of flammable or combustible atmospheres, disconnect power before servicing.

 **AVERTISSEMENT:** Pour éviter l'inflammation d'atmosphères inflammables ou combustibles, débrancher l'alimentation avant l'entretien.

Document Revision Level

This section provides a history of the revision changes to this document.

Revision	ECO Number	Date	Description
E	003187	5/01/2016	Vibration info added to sec 9

Revision History

[Click Here for Details](#)

Must check [Software](#) & [RF](#) compatibility before deployment!

1. COMPLIANCES/CONFORMITÉ

English

Important Information to the User

- This device **MUST** be professionally installed only by a factory representative or a trained authorized technician.
- Changes or modifications not expressly approved by the manufacturer may void the user's authority to operate the equipment.
- This device complies with Part 15 of the FCC Rules. Operation is subject to the following two conditions: 1) this device may not cause harmful interference, and 2) this device must accept any interference received, including interference that may cause undesired operation.
- This product contains a FHSS (Frequency Hopping Spread Spectrum) and FSK (Frequency Shifting Key) modulation RF transceiver for the 902-928 MHz ISM band, designed to meet FCC 15.247, and is used in industrial control and monitoring applications.
- To reduce potential radio interference to other users, install and use only the antenna supplied by the manufacturer to ensure successful communications.
- The antenna is factory sealed and **MUST NOT** be modified by the user.

FCC RF Exposure

To comply with FCC RF exposure compliance requirements, a separation distance of at least 20 cm must be maintained between the antenna of this device and all persons.

FCC Compliance Statement

This equipment has been tested and found to comply with the limits for a class B digital device, pursuant to Part 15 of the FCC Rules. These limits are designed to provide reasonable protection against harmful interference in a residential installation. This equipment generates, uses and can radiate radio frequency energy and if not installed and used in accordance with the instructions, may cause harmful communications to radio communications. However, there is no guarantee that interference will not occur in a particular installation. If this equipment does cause harmful interference to radio or television reception, which can be determined by turning the equipment off and on, the user is encouraged to try to correct the interference by one of the following measures:

- Reorient or relocate the antenna.
- Increase the separation between the equipment and receiver.
- Consult the manufacturer for technical help.

This equipment has been certified to comply with the limits for a class B computing device, pursuant to FCC Rules. In order to maintain compliance with FCC regulations, shielded cables must be used with this equipment. Operation with non-approved equipment or use of unshielded cables is likely to result in interference to radio and television reception. The user is cautioned that changes or modifications made to the equipment without the approval of the manufacturer could void the user's authority to operate this equipment.

CONFORMITÉ

Français

Informations importantes à l'utilisateur

- Ce dispositif doit être installé par un professionnel que par un représentant de l'usine ou par un technicien formé et autorisé.
- Les changements ou modifications non expressément approuvés par le fabricant peuvent annuler l'autorité de l'utilisateur à utiliser l'équipement.
- Cet appareil est conforme à la partie 15 des règles de la FCC. Son fonctionnement est soumis aux deux conditions suivantes: 1) ce dispositif ne doit pas causer d'interférences nuisibles et 2) cet appareil doit accepter toute interférence reçue, y compris les interférences qui peuvent causer un mauvais fonctionnement.
- Ce produit contient un FHSS (Frequency Hopping Spread Spectrum) émetteur-récepteur RF pour la bande ISM 902-928 MHz en utilisant FSK (Frequency Shifting Key) modulation, conçu pour répondre FCC 15.247, et est utilisé dans le contrôle industriel et les applications de surveillance.
- Pour réduire les interférences radio potentielles aux autres utilisateurs, installer et utiliser uniquement l'antenne fournie par le fabricant pour assurer une communication réussie.
- L'antenne est scellée en usine et ne doit être modifiée par l'utilisateur.

FCC RF Exposure

Pour se conformer à la FCC exigences de conformité de l'exposition, une distance de séparation d'au moins 20 cm doit être maintenue entre l'antenne de cet appareil et toutes les personnes.

Déclaration de conformité FCC

Cet équipement a été testé et déclaré conforme aux limites d'un appareil numérique de classe B, conformément à la partie 15 des règles de la FCC. Ces limites sont conçues pour fournir une protection raisonnable contre les interférences nuisibles dans une installation résidentielle. Cet équipement génère, utilise et peut émettre de l'énergie radiofréquence et, si non installé et utilisé conformément aux instructions, peut provoquer des communications nuisibles aux communications radio. Cependant, il ne est pas garanti que des interférences ne se produiront pas dans une installation particulière. Si cet équipement provoque des interférences nuisibles à la réception radio ou de télévision, ce qui peut être déterminé en mettant l'équipement hors et sous tension, l'utilisateur est encouragé à essayer de corriger l'interférence par une des mesures suivantes:

- Réorienter ou déplacer l'antenne.
- Augmenter la distance entre l'équipement et le récepteur.
- Consultez le fabricant de l'aide technique.

Cet équipement a été certifié conforme aux limites d'un dispositif informatique de classe B, conformément aux règles de la FCC. Afin de maintenir la conformité aux règlements de la FCC, des câbles blindés doivent être utilisés avec cet équipement. L'utilisation d'équipement ou l'utilisation de câbles non blindés non approuvé est susceptible d'entraîner des interférences dans la réception radio et télévision. L'utilisateur est averti que les changements ou modifications apportées à l'équipement sans l'approbation du fabricant pourraient annuler l'autorité de l'utilisateur à utiliser cet équipement.

2. CERTIFICATIONS

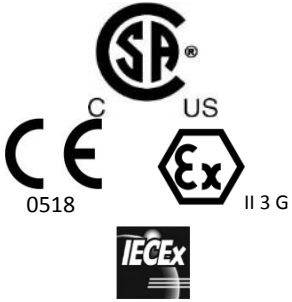

Class I Division 1, Groups A, B, C, D T3C
Class 1 Zone 0 AEx ia IIC T3 Ga; Class 1 Zone 0 Ex ia IIC T3 Ga
Tamb: -40 °C to +70 °C

ATEX ATEX: Sira 13ATEX2142X; Ex ia IIC T3 Ga; II 1 G
Tamb: -20 °C to +70 °C

IECEx SIR 13.0054X; Ex ia IIC T3 Ga
Tamb: -20 °C to +70 °C

INTRINSIC SAFETY CONTROL DRAWING

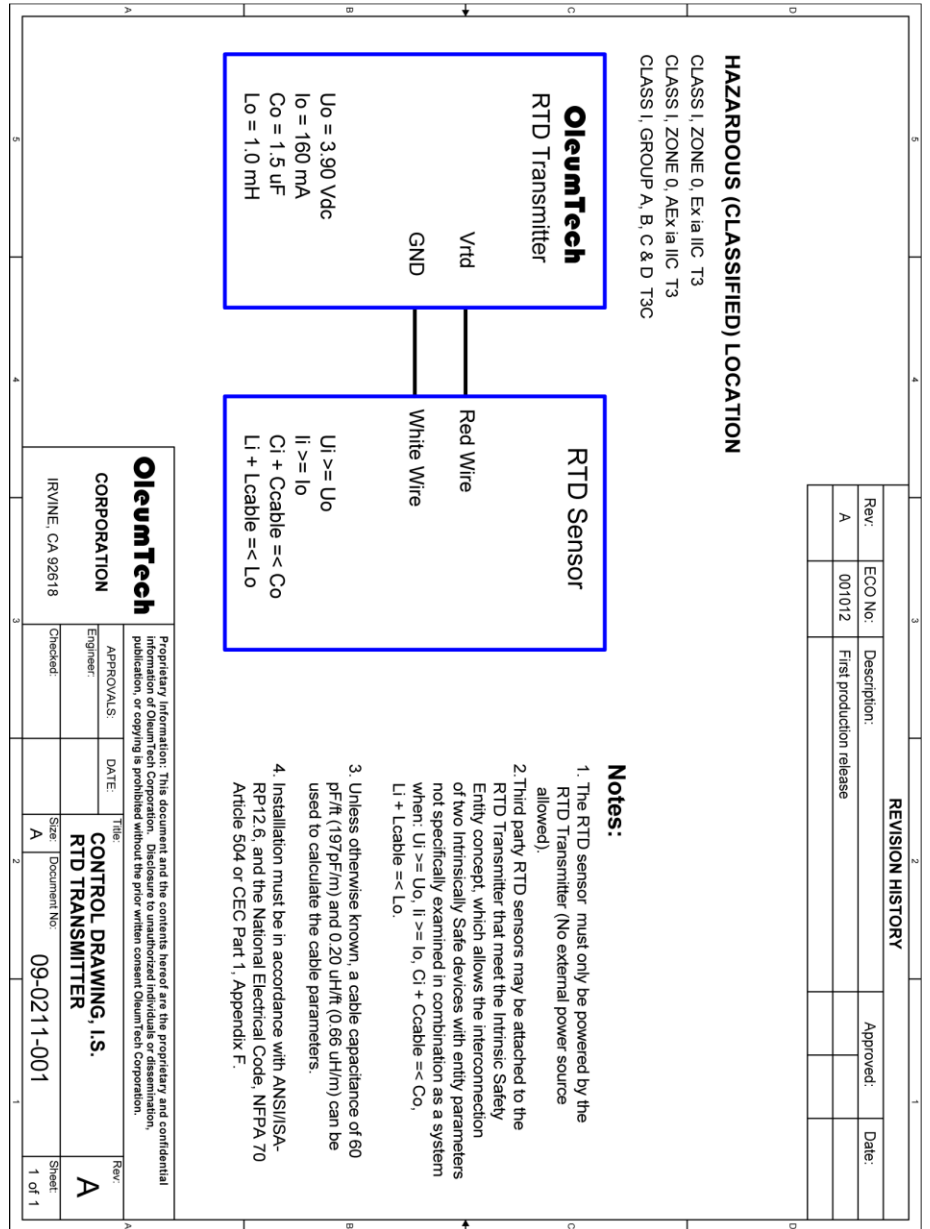

3. PRODUCT & SYSTEM OVERVIEW

The RTD Transmitter is part of the OleumTech Wireless Sensor and I/O Network. This device is designed for wirelessly monitoring temperature using a Platinum 100 ohm RTD sensor. Temperature value can be reported in Fahrenheit or Celsius.

The collected data is transmitted to a Wireless Gateway on to its Modbus Register Holding Table.

The stored data can be polled by a Modbus Master device such as a PLC, RTU, or EFM that is part of the operator's SCADA system. Once the data leaves the Gateway, the management of the data is decided by the user.

Unique Device Features

- Ideal for Monitoring Air, Gas, Water or Liquid Temperature
- Includes 4-wire RTD 100 Ohm Sensors (PT-100) (RTD)
- Supports Third-Party 3 or 4-Wire RTD 100 Ohm Sensors (PT-100) (RTM)
- RT1 Direct-Mount Version Ships with a 2" to 18" RTD Sensor / Custom Length Also Available (1/2" NPT Male)
- RT2 Multi-Vendor Version Includes Junction Box with Wiring Terminal Board (3/4" NPT Female)*
- 24-Bit ADC with $\pm 0.1^{\circ}\text{C}$ Accuracy
- User Selectable Display Units (Fahrenheit or Celsius)
- Measures Temperature Range from -65°F to 500°F (-55°C to 260°C)

SM Series Features

- Self-Contained, Battery-Powered
- 900 MHz / 2.4 GHz Option (Secure, ISM License-Free)
- Up to 7500 ft Wireless RF Range with Clear Line of Sight
- Serial Interface Also Available for Configuring Device via PC
- User-Friendly BreeZ® Configuration Software
- Intrinsically Safe for Use in Hazardous Areas - Class I; Division 1
- Secure Over-the-Air AES Encryption and Site Authentication

Wireless Solutions

- Reliable, Robust Wireless Performance
- Eliminates Costly Conduits and Wiring
- Monitor/Control Process Conditions 24/7
- Reduces Labor, Installation and Maintenance Costs
- Help Meet Regulatory Requirements
- Industrial Strength Performance and Durability

BreeZ® Configuration Software

- Microsoft Windows®-based software tool for configuring Wireless Devices such as Wireless Transmitters, Gateways, and I/O Expansion Modules
- Features Quick and Easy Project Creation Wizard
- Modbus Master Read/Write Function for Test Verification
- Allows Project Files to be Saved to and Retrieved from Gateway
- Easily Create Flexible/Sophisticated Network Architecture

4. HARDWARE OVERVIEW

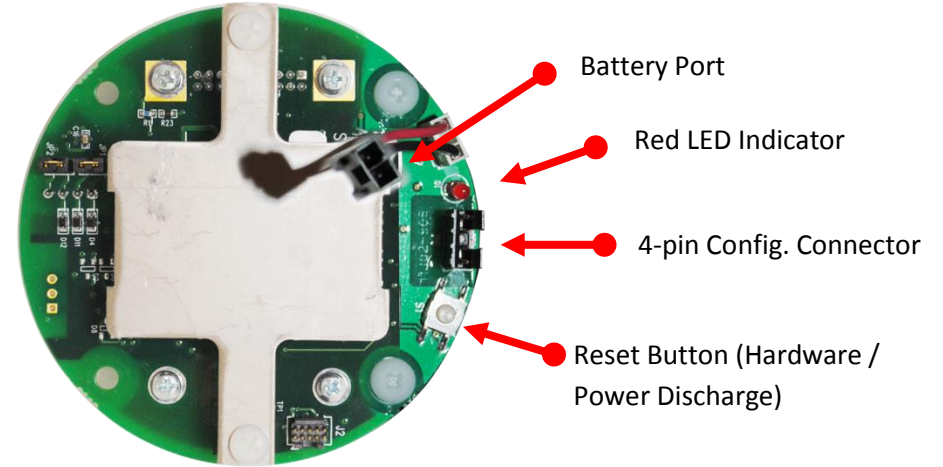
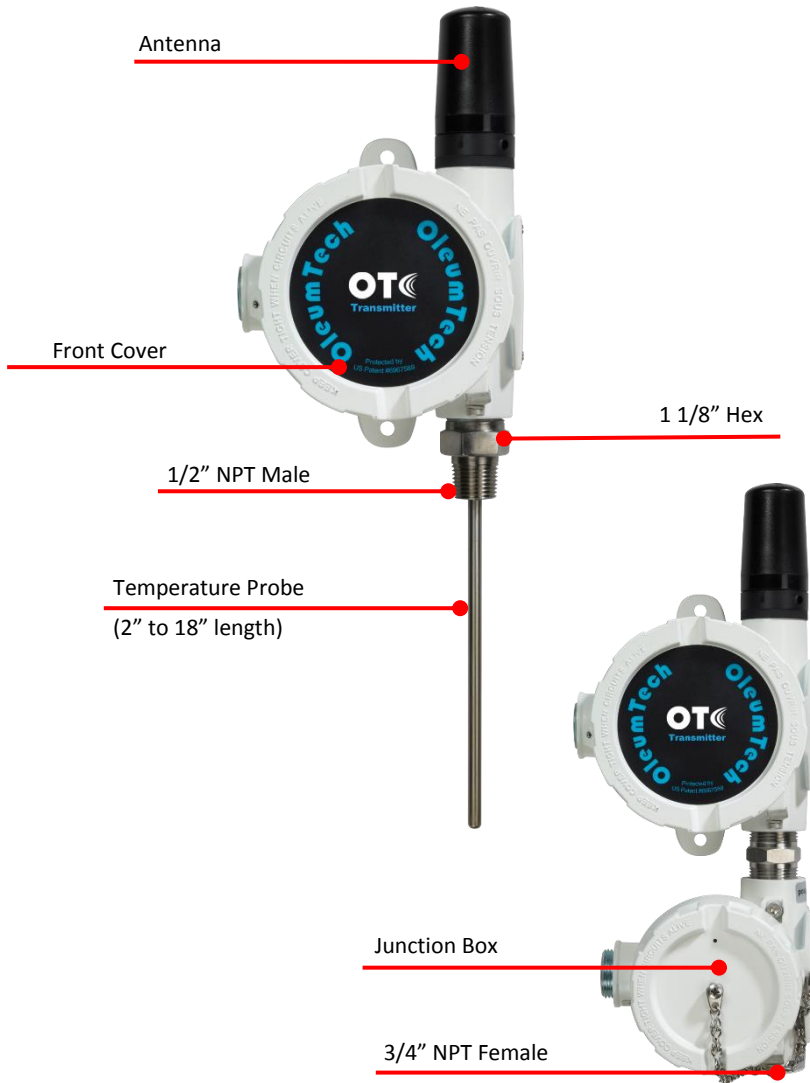

DIMENSIONS

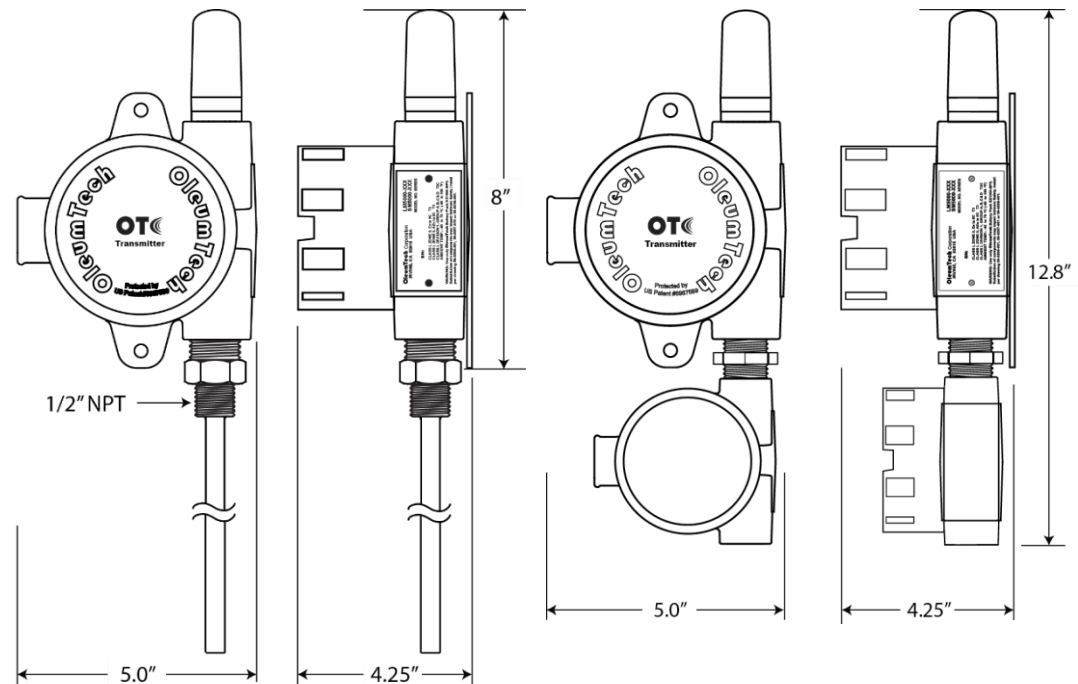

5. NETWORK DIAGRAM

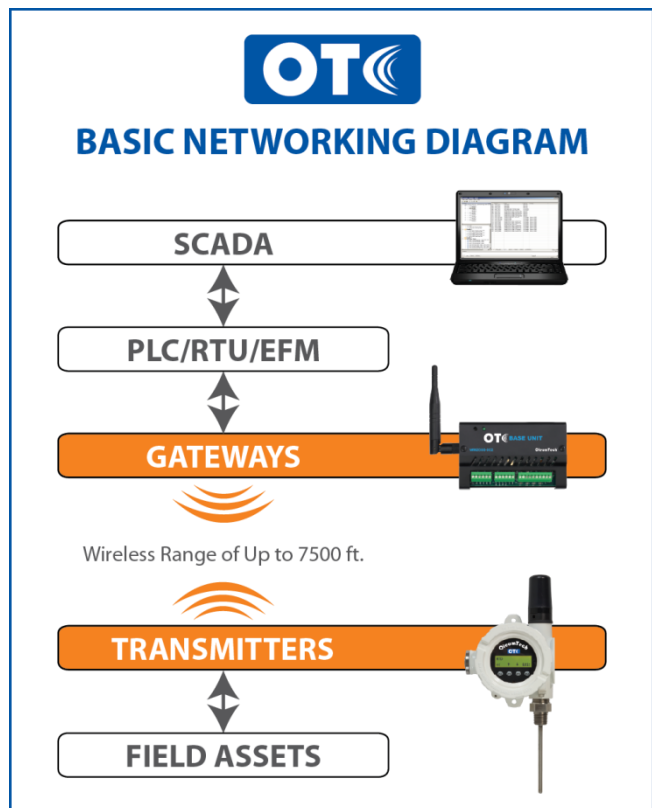

6. REQUIRED ITEMS FOR BASIC SETUP

Transmitter Setup

- RTD Transmitter
- Transmitter Battery Pack (Included with Transmitter)
- 100 ohm Platinum RTD Sensor (Included with Direct-Mount Version)

Gateway Setup

- Wireless Gateway
- Antenna for Gateway (Bulkhead, Omni, or Yagi)
- Antenna Cable (N to MMCX Connector)
- N to N Antenna Cable and Lightning Arrestor (Optional)
- External Power Source for Gateway (9-30 V)
- External Enclosure for Wireless Gateway

Configuration Cables

- USB to Serial Adapter (SX1000-CC9)
- Gateway Configuration Cable (SX1000-CC1)
- Transmitter Configuration Cable (SX1000-CC7)

Software and PC

- Latest BreeZ® Configuration Software
- Latest Gateway Firmware
- Latest Device Firmware Package
- PC with:
 - Microsoft Windows® Vista or Later
 - 1 GHz or Faster Processor
 - 256 MB or More RAM
 - 20 MB Hard Disk Space or More
 - USB or Serial Port

Modbus Master

- Modbus Master Device and Wiring (RS232 or RS485), RTU, PLC, HMI, etc...

Tools

- Screwdriver Set, Adjustable Wrench, Industrial-grade Thread Seal Tape/Thread Sealant (STL8 recommended)
- Any Other Tools Depending on Site and Equipment

Internet Access

- Internet access required for downloading software and Firmware

7. CONFIGURATION/INSTALLATION SEQUENCE

Configuration

1. Download and install latest BreeZ® Software v5.0 or higher to a PC
Download Center: <http://support.oleumtech.com>
(requires login credentials)
2. Check for latest Device Firmware on Download Center
3. Create a BreeZ® Project File
4. If upgrading Firmware, follow these instructions:
 - a. Physically Connect Device to PC and supply power
 - b. Open Connect screen and click “Flash”
 - c. Locate new Firmware file and click “Open”
 - d. DO NOT DISCONNECT OR TURN POWER OFF while upgrading Firmware (It may take a few minutes for upgrading process to finish)
 - e. Wait until LED turns off
5. Power up Gateway (9-30Vdc) and wait until boot-up sequence is complete (LED will turn off once boot-up is complete)
6. Connect PC to Gateway
 - a. USB to Serial Adapter (SX1000-CC9)
 - b. Gateway Configuration Cable (SX1000-CC1)
7. Identify COM Port for use in BreeZ® (Device Manager)
8. Select a Gateway in BreeZ® Project Tree
9. Update Gateway with BreeZ® Project File
10. Confirm Gateway “Configuration Download OK” in Build Tab Window in BreeZ®
11. Connect Wireless Transmitter to PC and Update It

Installation

For full instructions for setting up a Wireless Gateway, please refer to the Wireless Gateway User Guide(s).

1. Install Gateway inside NEMA enclosures
2. Follow best grounding practices
3. Setup and connect an Antenna with Lightning Arrestor to Devices
4. Connect Gateway to third-party Serial device(s)
5. Power up Gateway
6. Install Wireless Transmitter
7. Power up Transmitter
8. Power up/reboot any impacted sensors/devices if necessary
9. Verify RF and data communications
 - a. Use Modbus Register Polling and Write features in BreeZ®
 - b. Verify communication from third-party device(s) or SCADA system

8. BATTERY PACK INSTALLATION

1. Remove Front Cover



2. Connect Battery

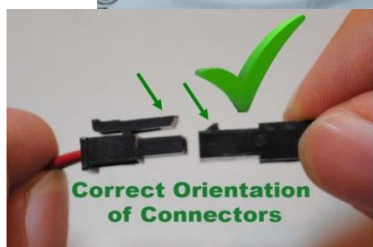

3. Secure Battery to Housing Using Supplied Velcro Strap
4. Securely Tighten Front Cover When Finished
5. Replace Battery When It Reads 2.9 V or Below

NOTE: Once a new Battery Pack is installed, it is perfectly normal to get a reading of 3.2 to 3.3 V.

This is due to the fact that the Transmitters take battery level while it is under load, providing a reliable method of monitoring battery health. Using the RF Timeout and RF Refresh tags along with battery voltage for monitoring device and RF communication health is strongly recommended.

If a new Battery Pack has been kept under storage or initially installed, battery level may need to be read a couple of times to ensure a stable accurate reading.

Store Battery in a cool, dry area when not in use.

[Click here to view Battery Life Chart](#)

Battery Depletion Chart from 2.9 V

Battery Voltage	Tx Interval	Duration Before Failure
2.9 V	1-second	1 hour
2.9 V	1-minute	2 days
2.9 V	5-minute	10 days
2.9 V	10-minute	20 days
2.9 V	15-minute	30 days

9. WIRING DIAGRAM – FOR MULTI-VENDOR TYPE

- The RTD Transmitter Can Be Used with a 3-Wire, or 4-Wire RTD Sensor. Please Follow the Wiring Table Shown Below.

	3-Wire (A)	3-Wire (B)	4-Wire (Default for Direct Mount Version "RT1")
Pin 1 (Red)	Red	White or Black	Red
Pin 2 (Yellow)	Red	White or Black	Red
Pin 3 (Blue)	N/A	N/A	White or Black
Pin 4 (White)	White or Black	Red	White or Black

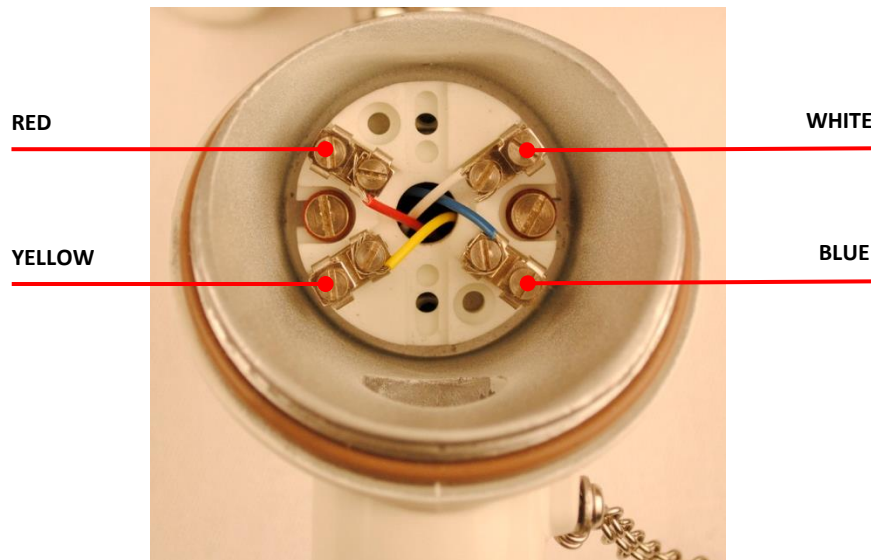

10. TRANSMITTER INSTALLATION

1. Direct Mount Version

- Apply Teflon® tape or appropriate sealant around threading
- Use a wrench to tighten Transmitter onto process (joint must be properly sealed)



2. Multi-Vendor Mount Version

- Mount RTD Transmitter to a bracket using 2 Mounting Holes (Optional)
- Apply Teflon® tape or appropriate sealant around sensor threading (STL8 recommended)
- Remove Junction Box cover and snake RTD Sensor wire through Junction Box opening
- Tighten Sensor to Transmitter, then connect wires
- Tightly close Junction Box cover (hand tighten only)
- Mount and tighten RTD Transmitter onto process (joint must be sealed properly)



Transmitter must be installed in upright position. Must apply industrial-grade thread seal tape or STL8 to threads.



3. Best Practice

- a. When attaching the Transmitter Cover or Junction Box Cover, be sure to check the O-Ring is seated properly. This step is critical in protecting the device from external moisture and other environmental factors. Over a long period of time, it may stretch and loosen, but it will function properly as long as the O-Ring is seated properly and flushed inside the Cover(s).



- b. Be sure to fully hand tighten the Cover(s).



- c. In the unlikely case when the O-Ring becomes unusable, please contact the RMA department for a replacement service.

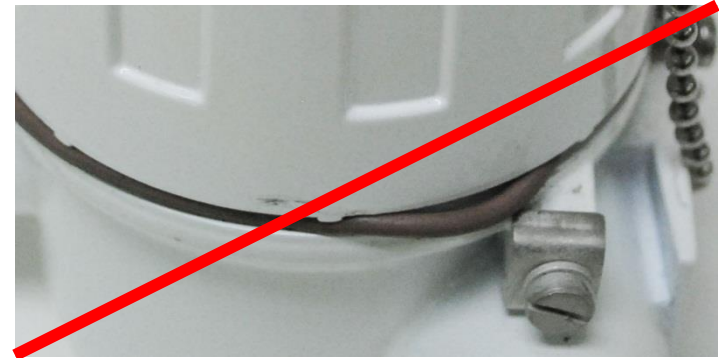

4. Vibration

OleumTech Transmitters have been tested to MIL-STD-810-F requirements. However, these devices are not intended for use on processes that have the potential to generate high vibration levels that would adversely impact product performance or life.

11. GROUNDING BEST PRACTICES

It is important to effectively earth ground the Transmitter to ensure safety, prevent static electricity damage and protection from lightning and/or electrical surges in the area. Ensure the tank to which the Transmitter is mounted is properly earth grounded as defined by the NEC.

- A true earth ground physically consists of a conductive pipe or rod driven into the earth. Rod electrodes shall not be less than 8 feet (2.44 m) in length and consist of the following materials and installed in the following manner:
- Electrodes shall be copper clad or their equivalent and shall be not less than 5/8 inch (15.875 mm) in diameter, or listed non-ferrous rods or their equivalent and not less than 1/2 inch (12.7 mm) in diameter.
- The electrode shall be installed such that at least 8 feet (2.44 m) of length is in contact with the soil. It shall be driven to a depth of not less than 8 feet (2.44 m). The electrode shall be driven at an oblique angle not to exceed 45 degrees from vertical or shall be buried in a trench that is at least 2 1/2 feet (.762 m) deep. The upper end of the electrode shall be flush with or below ground level. If ground end and the grounding electrode conductor attachment are above ground, ensure protection against physical damage.

Wireless Transmitter Grounding

- Ground the Transmitter to the tank using the grounding screw, or connect directly to the grounding rod if the mounting Transmitter on a non-metal tank. We recommend 12 to 16 AWG for ground cable. The grounding screw connections are located on the outside of the housing and identified by ground symbol .
- Once all wiring and grounding recommendations have been followed it is important to test the ground resistance at the grounding rod to assure a good ground. The most effective grounding method is direct connection to earth ground with minimal impedance. An impedance of less than 5 Ohms recommended.
- For more details on proper grounding electrodes and grounding electrode conductors, consult the National Electrical Code.

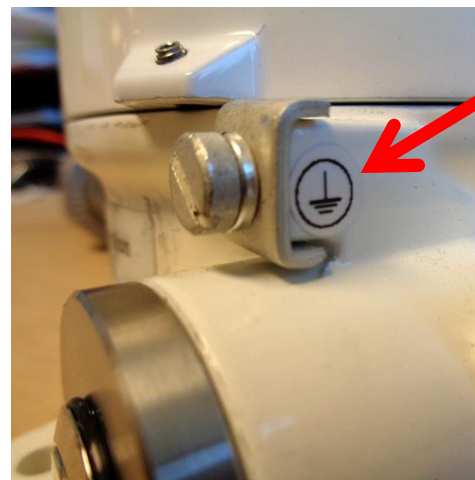

TERRE DES MEILLEURES PRATIQUES (Français)

Il est important de efficacement TERRE l'émetteur pour assurer la sécurité , prévenir les dommages de l'électricité statique et la protection contre la foudre et / ou les surtensions électriques dans la région. Assurer la citerne à laquelle l'émetteur est monté correctement relié à la terre tel que défini par la NEC.

- Une véritable prise de terre se compose physiquement d'un tuyau conducteur ou tige entraînée dans la terre. Électrodes de Rod ne sont pas moins de 8 pieds (2,44 m) de longueur et se compose des matières suivantes et installé de la manière suivante:
- Les électrodes doivent être en cuivre plaqué ou leur équivalent et ne doit pas être moins de 5/8 de pouce (15,875 mm) de diamètre, ou listé tiges non - ferreux ou leur équivalent et pas moins de 1/2 pouce (12,7 mm) de diamètre.
- L'électrode doit être installée de telle sorte que au moins huit pieds (2,44 m) de longueur est en contact avec le sol. Il est conduit à une profondeur d'au moins 8 pieds (2,44 m). L'électrode doit être conduit à un angle oblique de ne pas dépasser 45 degrés de la verticale ou sera enterré dans une tranchée qui est au moins 2 1/2 pieds (0,762 m) de profondeur. L'extrémité supérieure de l'électrode doit être de niveau avec ou au-dessous du niveau du sol. Si la fin du sol et le conducteur l'attachement de l'électrode de mise à la terre sont au dessus du sol, assurer une protection contre les dommages physiques.

Transmetteur sans fil à la terre

- Reliez l'émetteur vers le réservoir en utilisant la vis de mise à la terre, ou se connecter directement à la tige de mise à la terre si l'émetteur de montage sur un réservoir non métallique. Nous recommandons 12-16 AWG pour le câble de masse. Les connexions à vis de mise à la terre sont situés à l'extérieur du boîtier et identifiés par le symbole de terre .
- Une fois toutes les recommandations de câblage et de mise à la terre ont été suivies , il est important de tester la résistance du sol à la tige de mise à la terre pour assurer un bon sol. La méthode de mise à la terre la plus efficace est la connexion directe à la terre avec une impédance minimale . Une impédance inférieure à 5 Ohms recommandée.
- Pour plus de détails sur les électrodes de mise à la terre et de mise à la terre des conducteurs d'électrodes , consulter le Code national de l'électricité .



12. RF SETUP / RF SECURITY

Must check [Software](#) & [RF](#) compatibility before deployment!

1. Clear Line of Sight

Clear line of sight with minimal obstructions is necessary for best wireless (RF) communication. Performing a RF survey is highly recommended prior to commissioning.

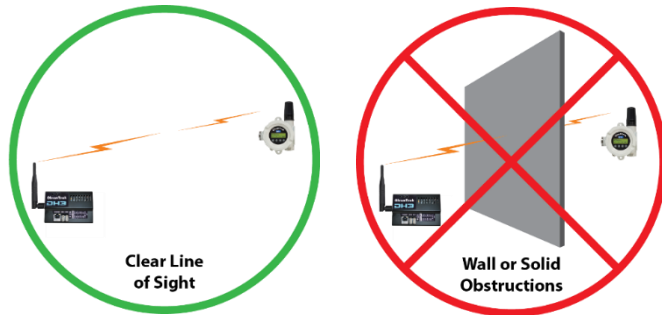

2. Maximum RF Range*

Below are typical RF ranges based on various types of antennas used with a Wireless Gateway.



FREQ/TYPE	BULKHEAD 3 dB	OMNI 25" 3 dB	YAGI 6dB
900 MHz @ 10 mW	5000 ft / 1.5 Km	7000 ft / 2.1 Km	7500 ft / 2.3 Km

FREQ/TYPE	BULKHEAD 2 dBi	OMNI 8 dBi	YAGI 19 dBi
2.4 GHz @ 63 mW	3281 ft / 1000 m	3 miles / 4.7 Km	4.3 miles / 7 Km

*Field tested with clear line of sight with antennas raised to 9 to 15 ft above ground at sea level (tested for point-to-point values only). Actual wireless RF range may vary depending on location, antenna and cable setup, and line of sight.

3. Use Received Signal Strength Indication (RSSI)

RSSI value can be exported as a Modbus register to monitor the RF health from end node(s) to Gateway.

RSSI Reading: Excellent = 40-75; Good = 76-90; Weak = 91-115

4. RF Timeout Tag

When setting up end nodes, RF Timeout tag can also be added as a Modbus register for monitoring RF health. Timeout trigger is normally set to three times the tx interval. This means when the data packet is missed on three consecutive intervals attempts, the RF timeout will be flagged.

0=RF OK; 1= RF Timeout

5. RF Refresh tag for ensuring RF and device health

6. Maximum Number of End Node Support per Gateway

Each Gateway can support a maximum of 63 end nodes. This can be a combination of Wireless Transmitters and Wireless I/O Modules.

The actual maximum number of End Nodes supported by a Gateway varies from site to site and project to project.

Major factors that contribute to actual support of maximum End Nodes depends on transmission frequency, RF frequency, RF propagation, RF data(bit) rate, and physical/geographical limitation or challenges as well as RF interferences.

If a Gateway is also connected wirelessly to other Gateways for peer-to-peer data sharing and control applications, achieving 63 maximum end node support may not be feasible due to limitation of RF budget, speed, and processing payload.

When a project requires usage of more than 10 end nodes per Gateway or is more complex than a basic Wireless Sensor Network that involves a Gateway and a handful of End Nodes, please consult with an OleumTech Application Engineer or a Certified Specialist to properly commission a project.

7. RF Enhancements

To ensure data reliability and delivery over RF, OleumTech Wireless Sensor and I/O Network provides RF collision detection for 900 MHz radio version and RF collision avoidance with 2.4 GHz radio version products.

8. RF Security

AES Encryption

OTC Wireless Sensor and I/O Network provides the ability to enable over-the-air encryption using AES. The 900 MHz radio version supports 256-bit AES encryption. Whereas the 915 MHz and 2.4 GHz versions support 128-bit AES encryption.

Implementing AES encryption requires firmware upgrade to following versions:

- BreeZ® Software v5.0 or higher
- DH3 v1.0 or higher
- Base Unit / DH2 / WIO® Gateway Module v2.0 or higher
- WT Series Transmitters v2.0 or higher
- SM/LM Series Transmitters v3.0 or higher
- Wireless I/O Modules v2.0 or higher

Must update all devices in the project.

If an existing site has been enabled with AES encryption, all wireless devices contained in that site must be updated with the revised BreeZ® project file for the new encryption method to take into effect. Otherwise, the wireless device that are not updated will not be able to communicate with devices that are updated.

Site Authentication

OleumTech Wireless Sensor and I/O Network also provides users to ability to enable Site Authentication. This method further extends security measures and eliminate or minimize cross-talk with neighboring networks.

How to Enable RF Security in BreeZ® v5.0 or higher

- (1) Open or create a BreeZ® project file (v5.0 or higher)
- (2) Right-click on “site” in project tree and select “edit”

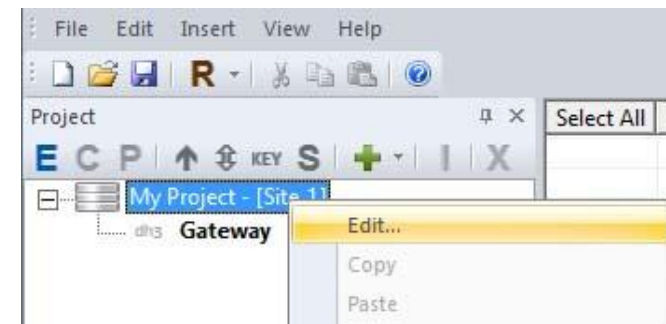

- (3) Check “Enhanced Site Security” to enable Site Authentication
- (4) Check “Enable AES Encryption” to enable AES encryption

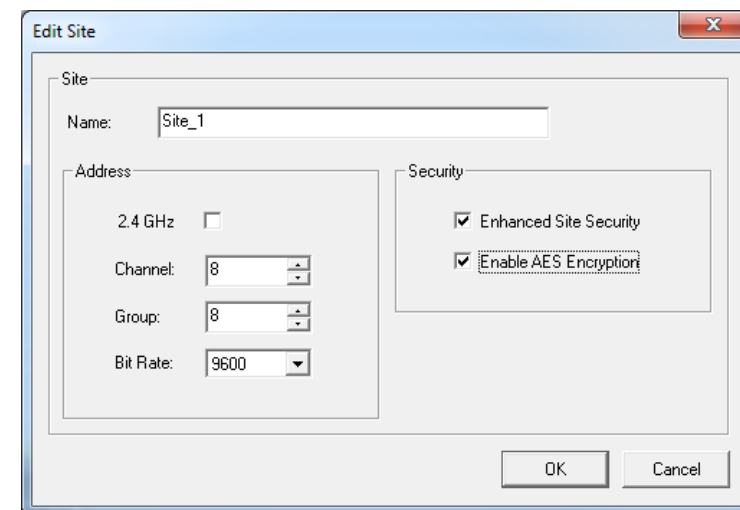

- (5) Save project file
- (6) Upgrade all wireless device firmware to version that supports AES
- (7) Update all wireless devices in the project file

13. DOWNLOAD & INSTALL BreeZ®

1. Go to OleumTech Download Center and Register
support.oleumtech.com
2. Download Latest BreeZ® Software Under “Products” After Being Granted Access to Download Center
3. Install BreeZ® Software on Your PC
4. Upgrade Wireless Gateway Firmware to Latest Version
5. Upgrade Wireless Transmitter Firmware to Latest Version

14. CREATE A PROJECT FILE USING BreeZ®

1. Open BreeZ® Software from Your PC



2. Click “New Project” in the Project Creation Wizard



3. Project Settings

Project Creation Wizard
Step 1
Identify the project.

Project

Project Name
My Project

File Location
\\otodc1\users\hkim\Desktop
Browse...

Project Name
Create your project name.

File Location
Click the "Browse" button and choose a location on your computer to store the Project File.

< Back Next > Finish Cancel

- Create a **Project Name**
- Select **File Location** by clicking Browse button
- Click **Next**

4. RF Settings

Project Creation Wizard
Step 2
Configure the initial site.

Radio (RF) Settings

Frequency
900 MHz

Channel
0

Group
0

Frequency
Select the Frequency that matches your WIO® wireless devices.

Channel: Select from 0-9 (900 MHz)
Multiple channels available for avoiding RF conflict with nearby sites.

Group: Select from 0-999
Group ID designation for gateways. By default, the first gateway you add to the site will be assigned to Group 0. Your second gateway to Group 1 and so on.

< Back Next > Finish Cancel

- Select **Frequency** that matches the Radio Frequency (RF) of the wireless devices
- Select **Channel** to avoid any RF conflict with any nearby sites
- Select **Group** - by default, the first Gateway you add to the site will be assigned to Group 0. The second Gateway added will be assigned Group 1 and so on.
- Click **Next**

5. Configure Primary Wireless Gateway

Step 3
Configure the primary gateway.

Gateway Name:

Gateway Type: Tx Power:

RTU Port: Slave ID:

Baud Rate: Config Port Mode:

Primary Gateway is the root receiver in a network. It connects to a RTU/EFM/PLC/DCS/HMI and acts as the collection point for all site end node information.

Type: Select Base Unit or DH2

Tx Power: Select desired power setting. Selecting higher Tx Power will consume more power.

RTU Port: Select RS232 or RS485. This port is used for connecting to a Modbus Master Device.

Slave ID: Select desired Slave ID

Baud Rate: Select Rate to match Master device

Config Port Mode: Modbus Slave or Debug. Modbus Slave: Modbus register polling enabled using gateway. Debug: Modbus register polling disabled using gateway.

< Back Next > Finish Cancel

- Create **Gateway Name**
- Select **Gateway Type**
- Select **Tx Power** - (Note: Selecting higher Tx Power consumes more power)
- Select **RTU Port** RS232 or RS485 (Terminal Block)
This port is used for connecting to a Master Device: PLC, RTU, DCS, HMI, or EFM.
- Select **Slave ID**
- Select **Baud Rate** that matches the Master device
- Select **Config Port Mode** (RS232): Modbus Slave - enables Modbus polling/writing feature using BreeZ®. Debug is only for advanced users and polling register capability is disabled.
- Click **Next**

6. Ethernet / RTU Port 2 Settings (DH3 only)

Step 3.a
Configure the primary gateway - DH3.

Gateway Name:

Gateway RTU Port 2: Slave ID:

Baud Rate: Ethernet:

IP Address: Subnet Mask: Default Gateway:

RTU Port 2: Select RS232 or RS485. This port is used for connecting to a Modbus Master Device.

Slave ID: Select desired Slave ID

Baud Rate: Select Rate to match Master device

Ethernet: Select DHCP or Static Address

Applies to Static Address Mode Only:
Enter IP Address
Enter Subnet Mask
Enter Default Gateway

< Back Next > Finish Cancel

- Select DHCP Client or Static IP Addressing
- If using Static Addressing, enter network information
- For help setting up Ethernet connectivity, please consult with your IT specialist

7. Add Transmitter

Step 4
Configure the RF transmitters.

Gateway Name:

RF Network Series: Transmitter:

Id	Transmitter

Select & Add Wireless Transmitter(s)
Non-LCD Version

- Analog / Pressure
- Cathodic Protection
- Discrete / High Level Switch
- Digital Level (Liquid - Magnetostrictive)
- Flow Totalizer (w/ LCD Gen1)
- LevelMate (Liquid)
- RTD Temperature
- Thermocouple

< Back Next > Finish Cancel

- Series** – Select Non-LCD
- Transmitter**: Select RTD
- Click **Add** button

8. Configure Transmitter – Part 1

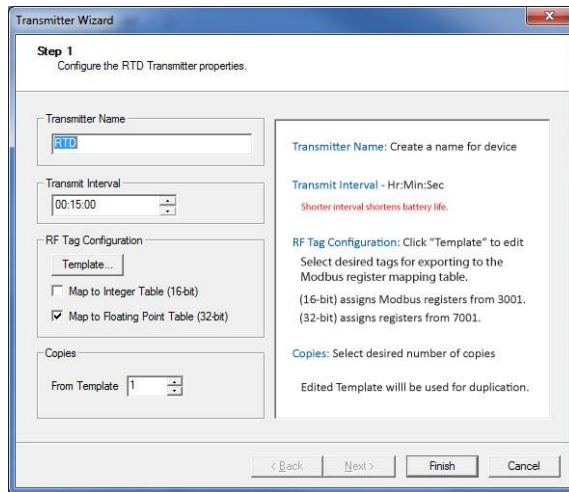

- a. Create **Transmitter Name**
- b. Enter **Transmit Interval** in Hr:Min:Sec
- c. Select **16-bit** or **32-bit** Modbus Mapping Table
 - i. 16-bit adds to 3000 block
 - ii. 32-bit adds to 7000 block
- d. **Copies**: Enter number of Transmitter copies you want to add to the project using the Template
- e. Click **Template**

NOTE: Once a new Battery Pack is installed, it is perfectly normal to get a reading of 3.2 to 3.3 V. This is due to the fact that the Transmitters take battery level while it is under load, providing a reliable method of monitoring battery health. Using the RF Timeout and RF Refresh tags along with battery voltage for monitoring device and RF communication health is strongly recommended.

If a new Battery Pack has been kept under storage or initially installed, battery level may need to be read a couple of times to ensure a stable accurate reading.



- f. Modify **Template** to desired settings
Exported tags will automatically be added to the Modbus Mapping Table
 - i. **Fahrenheit**: Temperature Unit
 - ii. **Celsius**: Temperature Unit
 - iii. **Battery Voltage**: Indicates Battery level: ≥ 2.9 V is good
 - iv. **RF Timeout**: 0 = RF OK ; 1 = RF Transmission Failure
 - v. **RSSI Value**: Received Signal Strength Indication (Transmitter to Gateway)
 1. Excellent signal = 40-75; Good signal = 76-90; Weak signal = 91-115
 - vi. **RF Refresh**: Helpful when trending RF data using a third party device

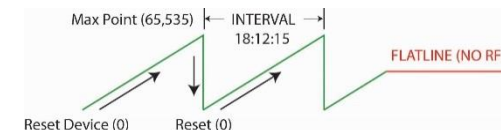

- vii. **Firmware Version**
- viii. **Error**: Helps diagnose problems using error codes
RTD Sensor Error Code 301: Cannot Detect RTD Sensor. Check RTD Sensor Cable Connection. If error persists, replace RTD sensor.

- g. Click **Apply**
- h. Click **Close** to exit Template window
- i. Click **Next**

9. Confirm Transmitter Addition

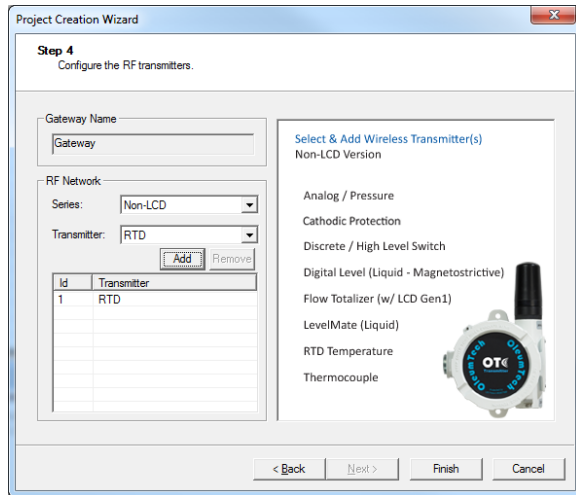

- a. Verify the added Transmitter in the Device Table
- b. Click **Finish**

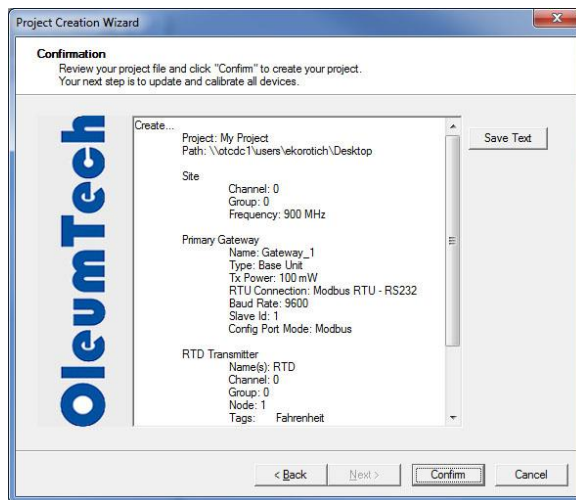

- c. Click **Confirm**

10. Verify Project File

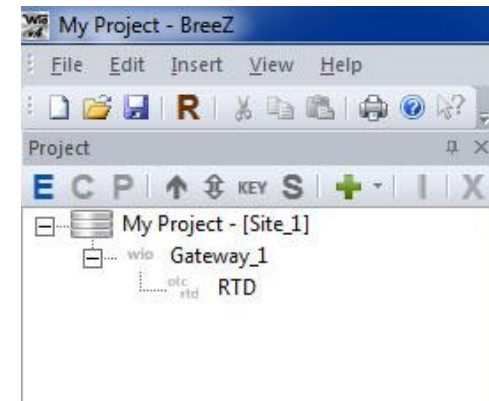

- a. Review **Project Tree** window
- b. To review or change device properties,
 - i. Click on the desired device in the Project Tree
 - ii. Click **E** (Edit) button

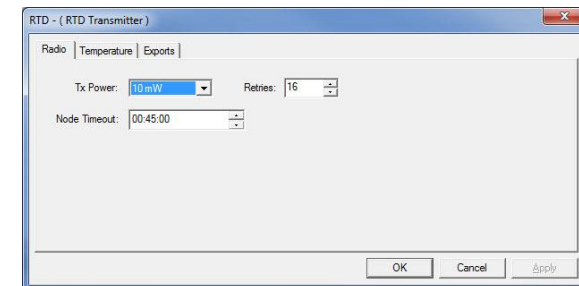

- c. To add another Transmitter or I/O Module,
 - i. Click on the Gateway in the Project Tree
 - ii. Click **+** (Insert) button
 - iii. Select desired device

- d. To add another Gateway,
 - i. Click on Site in the Project Tree
 - ii. Click  (Insert) button
 - iii. Select desired Gateway

- e. To rename a device,
 - i. Right-click over a device in the Project Tree
 - ii. Select Rename

- f. To remove a device from Project Tree,
 - i. Click on the desired device
 - ii. Click  (Delete) button

15. MANAGING MODBUS MAPPING TABLE

1. Double-click on Gateway in the Project Tree

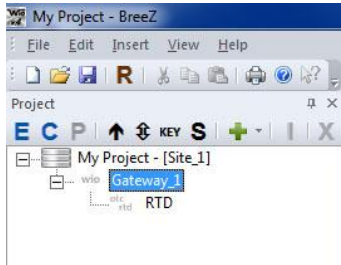

2. Click on Modbus Tab

Select All	Type	Register	Source	Point
001	Floating Point (32-...	7001	Gateway_1	RTD:Fahrenheit
002		7002	Gateway_1	RTD:Celsius
003		7003	Gateway_1	RTD:Battery Voltage
004		7004	Gateway_1	RTD:RF Timeout
005		7005	Gateway_1	RTD:RSSI Value
006		7006	Gateway_1	RTD:RF Refresh

At the bottom of the window, the 'Modbus' tab is selected among other tabs like Gateway_1, Imports, Exports, Outputs, and LevelMaster.

3. Edit Registers if Necessary

- a. Remove: Right-click over desired register and select Delete function
- b. Rearrange: Use click and drag function of mouse

4. Export Modbus Mapping Table to View Outside of BreeZ®

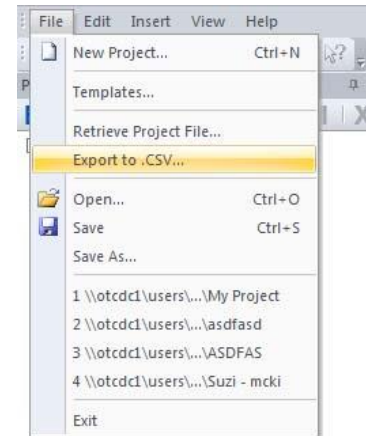

- a. Click on File menu
- b. Select "Export to .CSV..."
- c. Exported file gets saved automatically to the same directory as the Project File

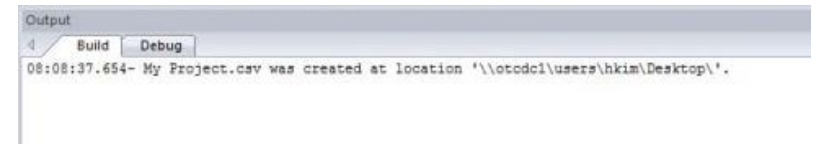

- d. You can also check the Output Build tab window for visual confirmation
- e. Recommend using MS Excel® for opening exported .csv file

16. SET UP COM PORT ON PC AND BreeZ®

1. Connect USB to Serial Adapter to PC's USB Port



2. Identify COM Port

- a. Open **Device Manager** on your PC (Using Windows 7)
 - i. Must have Admin rights to PC
 - ii. Click on Windows icon at bottom left corner of computer screen
 - iii. Type "device manager" in the search box

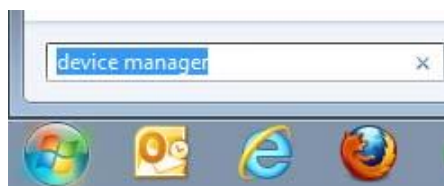

- iv. Press "Enter" on keyboard

v. Identify COM Port ID

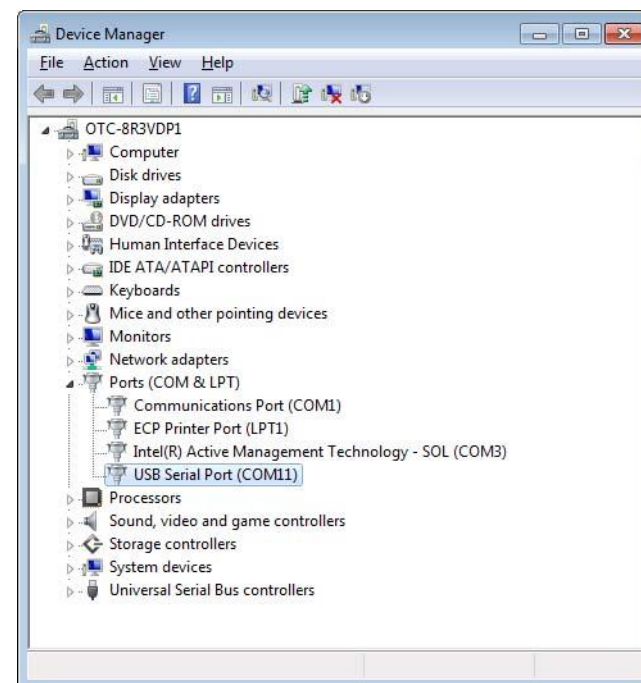

3. Select COM Port in BreeZ®

- a. Click **Edit** menu and select **Options**

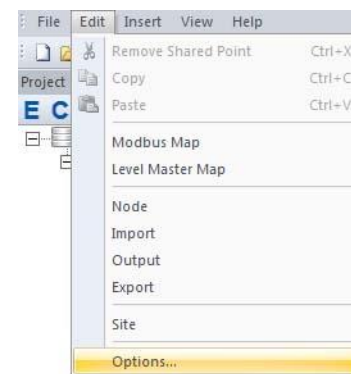

- b. Select COM Port ID that matches what you found in Device Manager
 - i. Use dropdown box to select COM Port

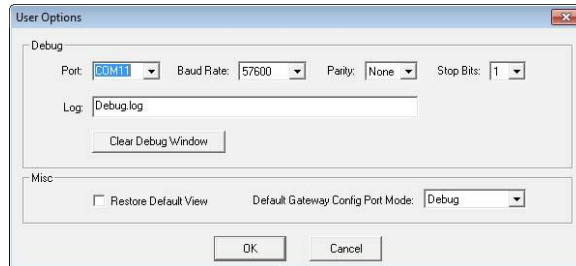

- c. **DO NOT CHANGE THE BAUD RATE!**
 - i. This baud rate setting is for your PC COM Port
 - ii. Wireless Transmitters are designed to only work with 57600 baud rate
 - iii. To change Modbus Master baud rate settings, you must edit it under Gateway properties

17. UPDATING TRANSMITTER

1. Remove Cover from Transmitter (Be Sure Battery Pack Is Connected)

2. Connect Transmitter to PC

a. Connect USB to Serial Adapter to PC



b. Connect Gateway Configuration Cable to USB to Serial Adapter



c. Connect Transmitter Configuration Cable to Gateway Configuration Cable



d. Connect Transmitter Configuration Cable to PCB



3. Update/Upload Transmitter Using BreeZ® Project File

- a. Click on Transmitter in the Project Tree
- b. Click  (Update Device) button

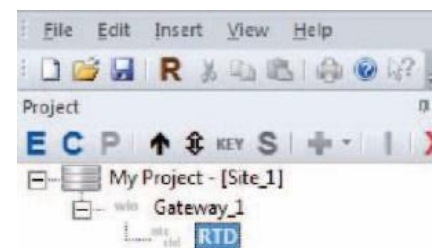

- c. If the Transmitter was used with another Project File, the Site Security Mismatch window will appear
 - i. Click **Ignore Key** to preserve existing key on the device
 - ii. Or, click **Update Key** to program key that matches the project file

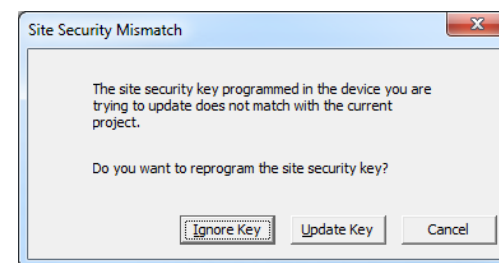

- d. Check **Output Build** window tab for visual verification of update

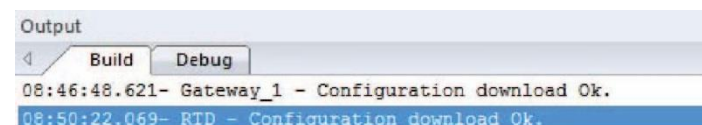

18. UPGRADING TRANSMITTER FIRMWARE

1. Download Latest Firmware Package
2. Connect Transmitter to PC Using Proper Cables
3. Open Project File in BreeZ® Software
 - a. Select Desired Transmitter in Project Tree, then Click “Connect to Device” icon

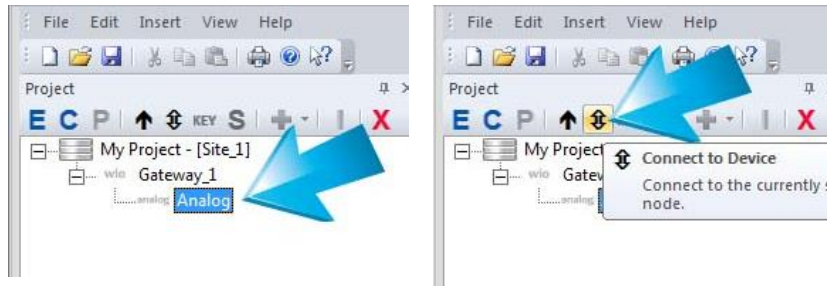

- b. Click on “Flash” Button Under Transmitter Tab

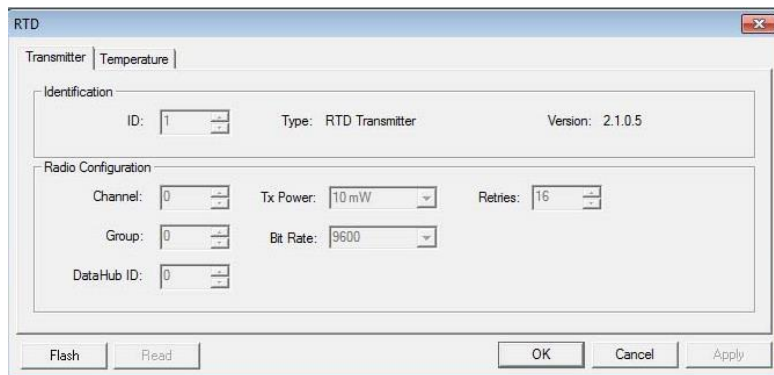

- c. Find and Select the Downloaded Firmware on PC and Click Open

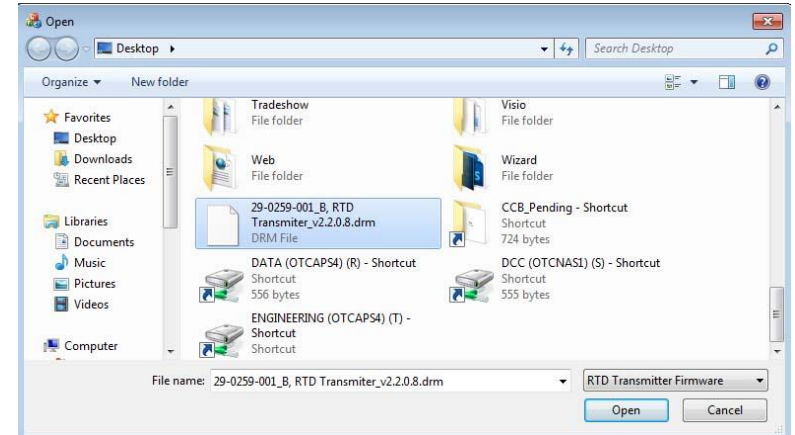

- d. Click “OK” to Continue Upgrading the Firmware to the Device

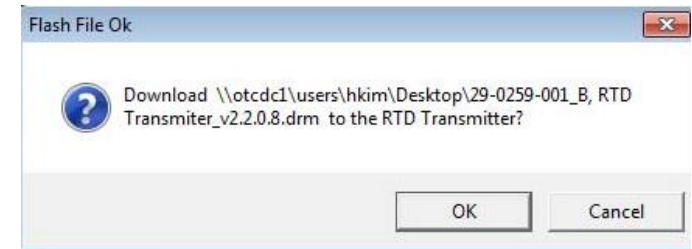

Do Not Disconnect Any Cables While Update is in Progress!

19. POLL MODBUS REGISTERS USING BreeZ® & GATEWAY

BreeZ® Software version 4.0 and higher provides users the ability to poll Modbus registers from a Wireless Gateway for installation verification.

This feature allows users to take poll once per command. Continuous polling is not available.

Single, multiple, or all registers can be selected for polling.

Use registers such as Battery Voltage, RF timeout, RF refresh, and RSSI values to determine device and network health.

When the Gateway's Config port is in Modbus Slave mode, the Debug mode is disabled and vice versa.

1. Open BreeZ® Project File on PC
2. Connect Gateway to PC Using Proper Cables
3. Click on Gateway in the Project Tree
4. Click  (Connect to Device) Button
5. Click on Config Port

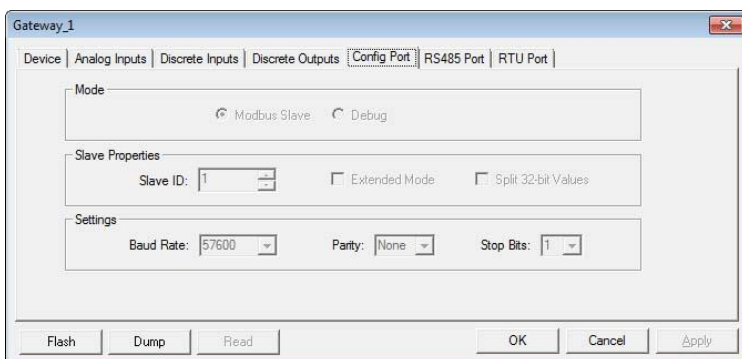

6. Verify the Gateway is in Modbus Slave Mode

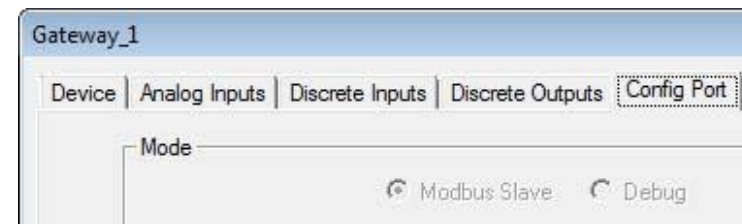

7. **If Gateway is Not in Modbus Slave Mode, Then:**

- a. Click Cancel to exit screen
- b. Click Gateway in the Project Tree
- c. Click "E" (Edit) button
- d. Click on Config port tab
- e. Change mode to Modbus Slave
- f. Click OK
- g. Click  (Update Device) button

8. Double-Click on Gateway in the Project Tree
9. Click on Modbus Tab
10. Select Desired Registers

11. Right-Click over Highlighted Area and Select Poll Modbus Register(s)

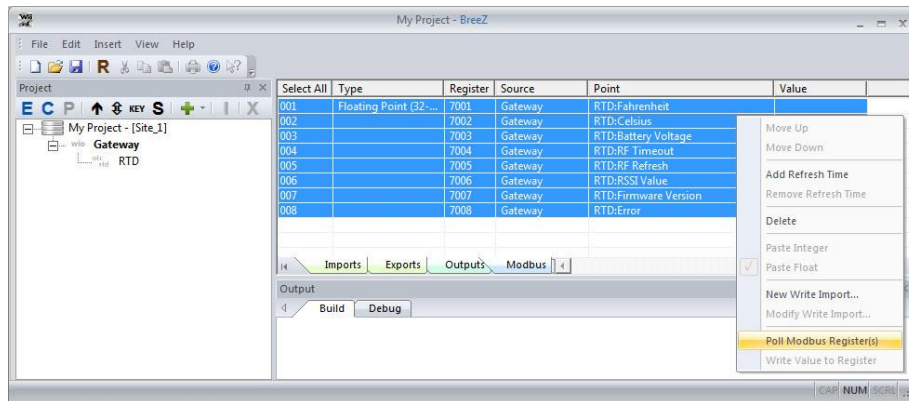

12. Look at Value Column for Details

Select All	Type	Register	Source	Point	Value
001	Floating Point (32-...	7001	Gateway	RTD:Fahrenheit	70.8461
002		7002	Gateway	RTD:Celsius	21.5812
003		7003	Gateway	RTD:Battery Voltage	3.2190
004		7004	Gateway	RTD:RF Timeout	0.0000
005		7005	Gateway	RTD:RF Refresh	19.0000
006		7006	Gateway	RTD:RSSI Value	40.0000
007		7007	Gateway	RTD:Firmware Version	80.0000
008		7008	Gateway	RTD:Error	0.0000

20. WIRELESS SITE SECURITY KEY

1. Default: When creating a new project file in BreeZ®, Site Security is automatically enabled
 - a. You can verify the status by viewing “Site” properties
 - b. Click “Site” in the project tree, then click E – Edit button
 - c. See Check Box under “Security”

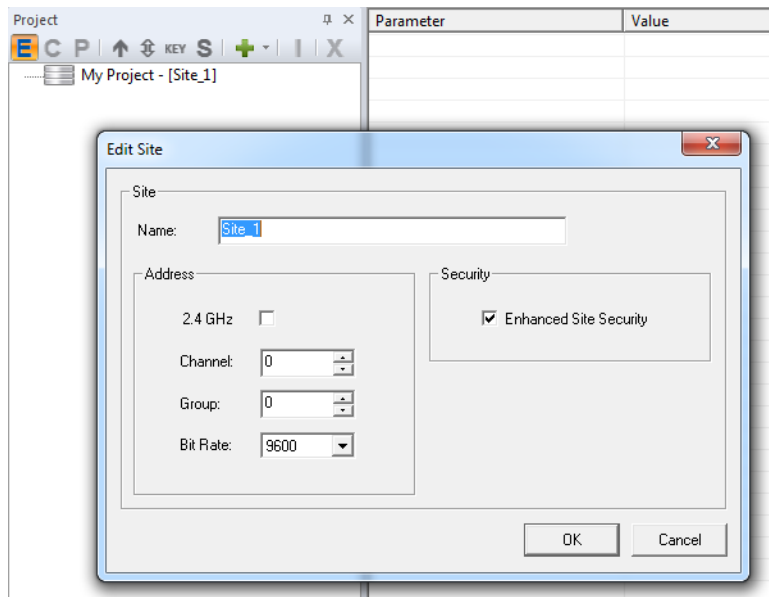

- d. Double-click on “Site” in the project tree and actual site key can be viewed

Parameter	Value
Project	My Project
Path	\\otcdc1\users\hkim\Desktop\My Project.brz
Location	
Site_1	CH 0 : GP 0 : BR 9600 : ESS On (Key: 1386171257) : 900 MHz

2. File Saving Behavior in Relations to Site Security



- a. Key will change when:
 - i. Saving a new project file in BreeZ
 - ii. Changing a BreeZ file name using Windows® (Modifying file name outside of BreeZ)
 - iii. Opening an existing file in BreeZ, then renaming and saving the file
 - iv. Using “Save As” feature in BreeZ, then saving file in a new directory
- b. Key will NOT change when:
 - i. Opening an existing file in BreeZ, modify it, then saving it
 - ii. Making no changes to a file, then saving or closing it
 - iii. Copying and pasting a project file in Windows

3. What To Do When Key is Lost

- a. If a key is lost or switched accidentally to an existing project file, the key can be retrieved from the Gateway
- b. Connect Gateway to PC
- c. Double-click on “Gateway” in the project tree
- d. Right-click on “Gateway”, then select “Read Site Security Key”

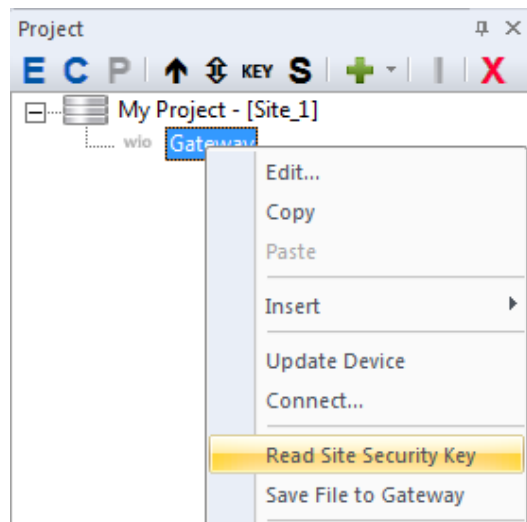

- e. Verify Build Tab Window

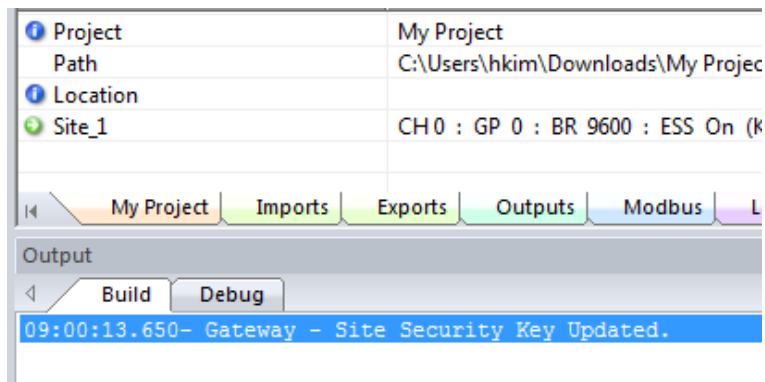

- f. Double-click on “Site” in the project tree and verify key change

Parameter	Value
Project	My Project 2
Path	\\otcdc1\users\hkim\Desktop\asdfasdfas.brz
Location	
Site_1	CH0 : GP 0 : BR 9600 : ESS On (Key: 1386282994) : 900 MHz

21. ERROR CODE TABLE

Error Code	Error Description	Required Action	Affected Parameters
0	No Issue	None	None
301	RTD Sensor Error: Cannot Detect RTD Sensor	Check RTD Sensor Cable Connection. If error persists, replace RTD sensor.	Fahrenheit, Celsius

22. TROUBLESHOOTING - TRANSMITTER

1. Battery and Power Input

Symptom:	Action/Resolution:
Battery voltage lower than 2.9V	<ul style="list-style-type: none"> Replace the Battery Pack if power level is less than 2.9 Volts.
Device does not power on	<ul style="list-style-type: none"> Verify the Battery Pack is securely connected to the device. Replace the Battery Pack.
Excessive battery drain	<ul style="list-style-type: none"> Set the retries to default. Increase the interval time. Check for Pressure Transducer defect.

2. Radio / Antenna

Symptom:	Action/Resolution:
No communication with Wireless Gateway	<ul style="list-style-type: none"> Confirm that Antenna has a clear line of sight to all devices. Reset the device. Site Security Key may not match Gateway and other devices. Update Site Security and update all devices with the same Project File. Increase the Tx Power to all devices. Antenna should be installed at 15 ft or higher for better line of sight.
Wireless communication cannot reach Wireless Gateway	<ul style="list-style-type: none"> Change the Bit Rate to the devices to 9600. Use a different Antenna type with higher gain for the Wireless Gateway.
Wireless communication is intermittent	<ul style="list-style-type: none"> Change the Bit Rate of the devices to 115200. Antenna should be installed at 15 ft or higher for better line of sight. Change the Channel of your Project File and update all of your system's devices. To eliminate possible crosstalk or radio interference with other sites in the area, verify Enhanced Site Security (ESS) is enabled.

3. Hardware Connection

Symptom:	Action/Resolution:
Device cannot communicate with BreeZ®	<ul style="list-style-type: none"> • Verify the Battery Pack is securely connected to the device. • Verify Configuration Cable is securely connected to the device and PC. • Verify the COM port settings in BreeZ® are correct. Verify the Baud Rate is 57600 and the Parity is 8-N-1. • Connect another Transmitter to verify communication with BreeZ® Software.
Issues with device wiring	<ul style="list-style-type: none"> • Verify the device wiring matches the wiring instructions in the User Guide. • Inspect and verify wiring has not been damaged. • Inspect and verify wiring is properly connected.
LCD display does not power on	<ul style="list-style-type: none"> • Verify the Battery Pack is securely connected to the device. • Check Transmitter for damages.

4. Configuration

Symptom:	Action/Resolution:
Transmitter is not communicating with Wireless Gateway	<ul style="list-style-type: none"> • Update all devices with the same Project File. • Confirm Antennas has a clear line of sight to all devices and are within approved distances. • Change the site Channel ID and update all devices. • Increase the Tx Power to all devices. • Confirm the Interval setting for the Transmitter and Gateway are correct. • Set the Retries to the default setting of 16 if it has been changed.
Device cannot communicate with BreeZ®	<ul style="list-style-type: none"> • Verify the Battery Pack is securely connected to the device. • Verify Configuration Cable is securely connected to the device and PC. • Verify the COM port settings in BreeZ® are correct. Verify the Baud Rate is 57600 and the Parity is 8-N-1. • Connect another Transmitter to verify communication with BreeZ® Software. • Replace the Battery Pack.
Error while updating the device but connection is still present	<ul style="list-style-type: none"> • Verify that the device has the latest Firmware revision. • Reset the device.

5. Measurement

Symptom:	Action/Resolution:
Transmitter reports incorrect measurements	<ul style="list-style-type: none"> • Check the Transmitter for damage or malfunctions. • Verify that the Sensor connected to the Transmitter can accept 9.5 VDC and has a current draw of 20mA or less.
RF Node Timeout fails	<ul style="list-style-type: none"> • Set 3x higher than the transmit interval time.
No Read Panel is displayed when taking a reading	<ul style="list-style-type: none"> • Verify Configuration Cable is securely connected to the device and PC. • Replace the Battery Pack. • No RF communication to the Gateway. Check the Gateway for proper configuration.
Measurements fluctuate	<ul style="list-style-type: none"> • Change the Channel of your Project File and update all of your system's devices. • To eliminate possible crosstalk or radio interference with other sites in the area, verify Enhanced Site Security (ESS) is enabled.

23. GENERAL MAINTENANCE

The RTD Transmitter is easy to maintain and does not require periodic system checks. Transmitter generally only needs a yearly visual inspection to monitor the following:

- Is the Battery life still 2.9 V or above? (Check more frequently if using shorter transmit interval)
- Is the RTD Transmitter still securely fastened to the mounting location?
- Are there any visible signs of corrosion, cracks or residue build-up on the unit?
- Has anything about the intended use of the original application changed?

If the RTD Transmitter is securely fastened, with no signs of corrosion, cracks, or residue build-up, or if nothing has changed about the location of its intended use, it should continue to operate within designed specification.

If the RTD Transmitter is not securely fastened; if there are signs of corrosion, cracks, residue build-up; or if there has been a change to the location of its intended use resulting in undesirable performance, contact the manufacturer for service instructions.

Cleaning: To prevent static discharge, wipe the outer casing with a damp cloth only.

24. GLOSSARY

16-Bit Integer - a unit of digital information comprised of 16 bits which may be interpreted as: *Unsigned:* 0 to 65,535 ($2^{16}-1$) or *Signed:* $-32,768$ ($-(2^{15})$) to $32,767$ ($2^{15}-1$) value.

32-Bit Float - a method of representing [real numbers](#) in a way that can support a wide range of values..

Analog Signal - any [continuous signal](#) for which the time varying feature (variable) of the signal is a representation of some other time varying quantity, i.e., analogous to another time varying signal. For example, in sound recording, fluctuations in air pressure strike the diaphragm of a [microphone](#) inducing fluctuations in current produced by its coil. This current is said to be an "analog" of the sound.

Analog Input - a method for measuring an analog signal.

Analog Output - a method for producing an analog signal.

ASCII - The American Standard Code for Information Interchange, is a character-encoding scheme based on the ordering of the English alphabet. ASCII codes represent text in computers, communications equipment, and other devices that use text.

Baud Rate - A number related to the speed of data transmission in a system. The rate indicates the number of electrical oscillations per second that occurs within a data transmission. The higher the baud rate, the more bits per second are transferred.

Bias - while scaling an analog input, the value added to offset the range. Example: range = 500, bias = 100, analog input values scale from 100 (min) to 600 (max).

Bit - a contraction of binary digit, is the basic unit of [information](#) in [computing](#) and [telecommunications](#); it is the amount of information stored by a digital device that exists in one of two possible distinct [states](#) 1 or 0, On or Off, etc...

Bit Rate - RF data rate or rate that RF data is transmitted over-the-air (9.6k, 115.2k-900MHz or 250k-2.4MHz).

Byte - unit of digital information in computing and telecommunications that most commonly consists of eight bits.

Channel - one of either 10 hopping sequences (900MHz) or 12 direct sequence channels (2.4GHz) used to isolate radio communications.

COM Port - a serial communication physical interface through which information transfers in or out one bit at a time.

Configuration Port - the COM Port used to configure an OleumTech device.

Count All - a method for increasing an unsigned 16 bit integer each time a discrete input is opened or closed (2 counts).

Count High - a method for increasing an unsigned 16 bit integer each time a discrete input is closed (1 count).

Count Low - a method for increasing an unsigned 16 bit integer each time a discrete input is opened (1 count).

CTS - clear to send, a discrete signal indicating permission from the DCE for the DTE to send data to the DCE.

DCE - Data Communication Equipment *i.e.* computers and other intelligent devices.

Debounce - the duration of time (ms) in which a discrete signal must remain stable prior to acknowledging a change in state from "On/Closed" to "Off/Open" and vice versa.

Debug - output to the Configuration Port from a connected device providing user insight into its status and operation.

Digital (Discrete) Signal - an electrical signal whereby minor fluctuations of the signal are not meaningful unless they cross above or below a discrete threshold, at which point they are said to be "On/Closed" or "Off/Open."

DIN Rail Mount - Metal rail of a standard type widely used for mounting circuit breakers and industrial control equipment inside equipment racks.

Discrete Input - a method for measuring a digital (discrete) signal.

Discrete Output - a method for producing a digital (discrete) signal.

Discrete Switch - a device that produces a digital (discrete) signal represented in 0 or 1 for exception reporting purposes.

DTE - Data Terminal Equipment *i.e.* modems, terminals and any other unintelligent device.

Dual Float (Configuration) - Liquid Level Sensor or High Level Switch Sensor set up with two floats to read either product level and interface level liquid levels, or for high and high-high alert notification.

EFM - Electronic Flow Meter.

End Node - OleumTech network device that monitors process conditions.

Enhanced Site Security - Enabling site security reduces the chance that transmitted information can be accessed by unauthorized devices or cross-talk between other devices operating in the area. By default, site security is enabled and it is recommended to keep this default setting.

Error - Status of the last read operation performed by a Transmitter. A status of 0 = OK.

Exports - Values sent to other devices in wireless network.

Extended Mode - Used to set a slave ID higher than 255.

Full Duplex - Four wire communication mode using handshaking.

Ground (GND) - Ground or earth may be the reference point in an electrical circuit from which other voltages are measured, or a common return path for electric current, or a direct physical connection to the Earth.

Group - ID used to configure one or more wireless gateways with its end nodes in a network.

Half Duplex - Two wire communication mode which does not use handshaking.

Handshaking - An automated process of negotiation that dynamically sets parameters of a communications channel established between two entities before normal communication over the channel begins.

Host - Wireless ID of receiver.

Imports - Values received from other devices in wireless network.

Initially On - Upon Power cycle or updating device, the discrete output will be closed.

Interface (Level) - Second level of fluid in tank such as water. Represented by the position of the lower float on the digital liquid level sensor.

Interval - Time delay in which the device will transmit data.

Jumper - A short length of wire used temporarily to complete a circuit or to bypass a break in a circuit. Represented by small pieces placed on pins of the circuit board.

Modbus - A Master/Slave protocol used with programmable electronic devices that allows for communication between many devices connected to the same network.

Modbus Master - A device that polls (requests and sends) information from one or more Slave devices in a Modbus network.

Modbus Module - Used when a port on a receiver is set to Modbus Master mode. Used to read and write values to a Modbus Slave device.

Modbus Slave - A device in a Modbus network takes action from a Modbus Master device and responds to it.

Node - term used to identify a System Transmitter, configured to communicate with a System Gateway.

Node Timeout - Transmitter setting that specifies the number of minutes the node checks for radio-frequency activity. If it does not detect radio-frequency activity within this period, it registers a Read Timeout error.

Normally Closed - Digital contact that is closed in normal state.

Normally Open - Digital contact that is open in normal state.

Output Window - shows messages and data associated with various tasks.

Outputs - Values used to source outputs on a device such as analog output, discrete output, or Modbus write registers.

Parity - A bit added to a binary code that indicates parity and is used to check the integrity of data. A parity bit is used as the simplest form of error detecting code.

PLC - Programmable Logic Controller.

Port - Communications Port ID on computer used to configure devices.

Pressure Transducer - Device used to convert pressure to an analog value.

Product (Level) - Top level of fluid in tank such as oil. Represented by the position of the top float on a digital liquid level sensor.

Project Explorer - Window in the BreeZ® Software that shows a tree of the devices in a project file. The name of the project file (current site) appears at the top of the tree, followed by the Wireless Gateway associated with the project file. Transmitters and Modules are grouped below the Wireless Gateway to which they are assigned.

Project File - Site specific project configuration set up and saved using BreeZ® software.

Project Name - Name assigned to field site specific project set up and saved using BreeZ® software.

Pulsed - The discrete output will change state for a specified period of time determined by a Modbus master via a Modbus register write. The value written will be in milliseconds.

Range - Max decimal value to be represented by full scale of analog input.

RAW Units - Digital representation of an analog signal.

Refresh Time - Count that increases every one (1) second. The count is posted each time the corresponding device completes a successful transmission. An unchanging refresh time indicates a failure of the corresponding device.

Relay - A device, usually consisting of an electromagnet and an armature, by which a change of current or voltage in one circuit is used to make or break a connection in another circuit or to affect the operation of other devices in the same or another circuit.

Retries - Number of times the device will send data in the event of a transmission failure before terminating transmit attempts.

RF Timeout - diagnostic indicator for radio communication. To use this value, set the Node Timeout in transmitter's radio setting to double that of the Reading Interval time plus 10 seconds.

RS485 - Telecommunications standard for binary serial communications between devices. RS485 allows for serial connections between two or more than devices on a networked system.

RS485 Port - RJ45 Jack located on top of Base Unit and Modules, used to communicate Modbus via RS485 protocol.

RTS - Ready To Send (232 mode).

RTU - Remote Terminal Unit.

RTU Port - Green terminal ports on Base Unit & DH2, used to communicate Modbus via RS485 or RS232 protocol.

RX - Receive (RS232 mode).

RX- - Receive Minus (RS485 mode).

RX+ - Receive Plus (RS485 mode).

Scaled Units - Used to convert an analog signal into desired values.

Single Float (Configuration) - Liquid Level Sensor or High Level Switch Sensor set up with one float to read either level liquid levels or for alert notification.

Site - Field location where devices are deployed for use.

Site ID - Unique, customer assigned identification for site location.

Slave ID - ID of the slave device in which Modbus Registers are being requested.

Solenoid - A coil of wire, partially surrounding an iron core that is made to move inside the coil by the magnetic field set up by a current: used to convert electrical to mechanical energy, as in the operation of a switch.

Span - Digital Range of analog to digital converter. Used to signify voltage range of device being used.

Split 32-Bit Values - Used to take a 32 bit float register and divide it into two 16 bit registers.

Stop Bits - Bits sent at the end of every character to allow the receiving signal hardware to detect the end of a character and to resynchronize with the character stream.

Turbine - Device that produces digital pulses proportional to the rate at which fluid passes through it.

TX - Transmit (RS232 mode).

TX- - Transmit Minus (RS485 mode).

TX Power - Power level at which the radio transmits.

TX+ - Transmit Plus (RS485 mode).

V+ - Positive voltage.

Valve - Used to control the flow of liquids or gas.

Voltage - Electrical potential or potential difference expressed in volts.

25. ATEX / IECEx INSTRUCTIONS

The following instructions apply to equipment covered by certificate number Sira 13ATEX2142x

- a. The equipment may be used with flammable gases and vapours with apparatus groups IIB or IIC and with temperature classes T3.
- b. The equipment is only certified for use in ambient temperatures in the range -20 °C to +70 °C and should not be used outside this range.
- c. The certificate number has an 'X' suffix which indicates that special conditions of installation and use apply. Those installing or inspecting this equipment must have access to the contents of the certificate.
 - b. Installation shall be carried out in accordance with the applicable code of practice by suitably-trained personnel
 - c. Repair of this equipment shall be carried out in accordance with the applicable code of practice.

If the equipment is likely to come into contact with aggressive substances, then it is the responsibility of the user to take suitable precautions that prevent it from being adversely affected, thus ensuring that the type of protection is not compromised.

- *Aggressive substances - e.g. acidic liquids or gases that may attack metals, or solvents that may affect polymeric materials.*
- *Suitable precautions - e.g. regular checks as part of routine inspections or establishing from the material's data sheet that it is resistant to specific chemicals.*

Repair of this equipment shall be carried out in accordance with the applicable code of practice.

The certification marking shall be as detailed on drawing number 67-1004-001 below:

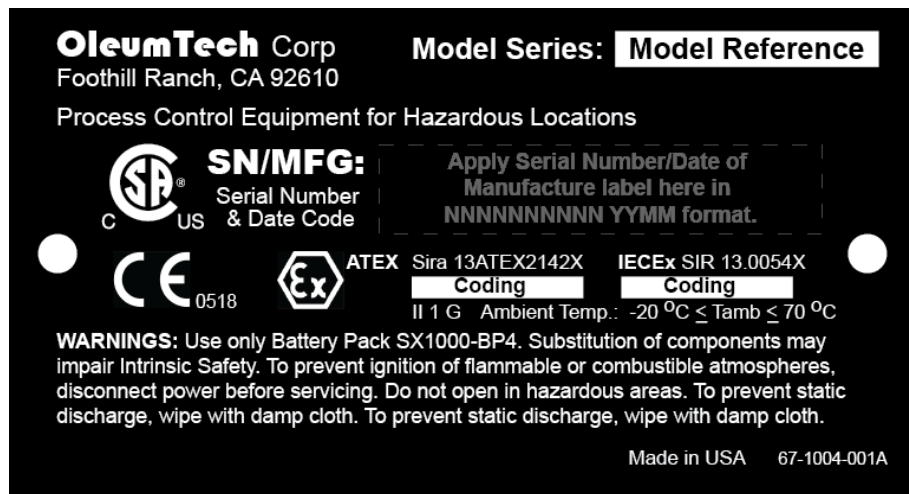

Additional information

1. A copy of the EC type examination certificate, Sira 13ATEX2142X can be located [here](#) at www.oleumtech.com.
2. A copy of the IECEX SIR 13.0054X can be located [here](#) at www.oleumtech.com.

OR

3. Add a copy of the EC type examination certificate, Sira 14ATEX4143X can be located [here](#) at www.oleumtech.com.
4. A copy of the IECEX SIR 13.0055X can be located [here](#) at www.oleumtech.com.

(ATEX/IECEX) Special Conditions For Safe Use

- I. *The enclosure is manufactured from aluminum. In rare cases, ignition sources due to impact and friction sparks could occur. This shall be considered during installation, particularly if the equipment is installed in a Zone 0 location.*

- II. *Under certain extreme circumstances, the exposed non-metallic antenna cover may store an ignition capable level of electrostatic charge. Therefore, the user/installer shall implement precautions to prevent the buildup of electrostatic charge, e.g. locate the equipment where a charge-generating mechanism (such as wind-blown dust) is unlikely to be present and clean with a damp cloth. The enclosure shall be earthed to the local metalwork.*

26. LIMITED WARRANTY

- a. OleumTech warrants that goods described herein and manufactured by OleumTech are free from defects in material and workmanship for two (2) years from the date of shipment. Batteries are expressly excluded from this warranty. Battery life and replacement batteries may be warranted under separate agreement depending on specific customer needs and applications.
- b. OleumTech warrants that goods repaired by it pursuant to the warranty are free from defects in material and workmanship for a period to the end of the original warranty or ninety (90) days from the date of delivery of repaired goods, whichever is longer.
- c. Warranties on goods not manufactured by OleumTech are expressly limited to the terms of the warranties given by the manufacturer of such goods.
- d. All warranties are void in the event that the goods or systems or any part thereof are (i) misused, abused or otherwise damaged, (ii) repaired, altered or modified without OleumTech's consent, (iii) not installed, maintained and operated in strict compliance with instructions furnished by OleumTech, (iv) worn, injured or damaged from abnormal or abusive use in service time, (v) subjected to acts of God, or extreme weather phenomenon including, but not limited to, flood, lightning, tornado or hurricane, or (vi) intentional acts including, but not limited to vandalism, sabotage, explosion or acts of terrorism.
- e. THESE WARRANTIES ARE EXPRESSLY IN LIEU OF ALL OTHER WARRANTIES EXPRESSED OR IMPLIED (INCLUDING WITHOUT LIMITATION WARRANTIES AS TO MERCHANTABILITY AND FITNESS FOR A PARTICULAR PURPOSE), AND NO WARRANTIES, EXPRESSED OR IMPLIED, NOR ANY REPRESENTATIONS, PROMISES, OR STATEMENTS HAVE BEEN MADE BY OLEUMTECH UNLESS ENDORSED HEREIN IN WRITING. FURTHER, THERE ARE NO WARRANTIES, WHICH EXTEND BEYOND THE DESCRIPTION OF THE FACE HEREOF. ANY WARRANTIES BEYOND THOSE SET FORTH HEREIN MUST COME DIRECTLY FROM OLEUMTECH.

27. REVISION HISTORY

Revision C

Document completely rewritten

Revision D

Added ATEX/IECEX special conditions for safe use – sec 25

Revision E

Vibration info added to sec 9

OleumTech Corporation
19762 Pauling Way
Foothill Ranch, CA. 92610
Phone: 866.508.8586 • 949.305.9009
Fax: 949.305.9010
www.oleumtech.com

OleumTech has made a good faith effort to ensure the accuracy of the information in this document and disclaims the implied warranties of merchantability and fitness for a particular purpose and makes no express warranties, except as may be stated in its written agreement with and for its customers.

OleumTech shall not be held liable to anyone for any indirect, special or consequential damages due to omissions or errors. The information and specifications in this document are subject to change without notice.

Copyright © 2016. All Rights Reserved.

OleumTech and BreeZ® are registered trademarks of OleumTech Corporation. Other trademarks and registered trademarks are the property of their respective owners.

OleumTech RTD Transmitter User Guide

5/01/2016

Document number: 80-7017-001_E