

# USER MANUAL for temperature and humidity transducer

## TRS-04a

firmware version: 2.04 or higher

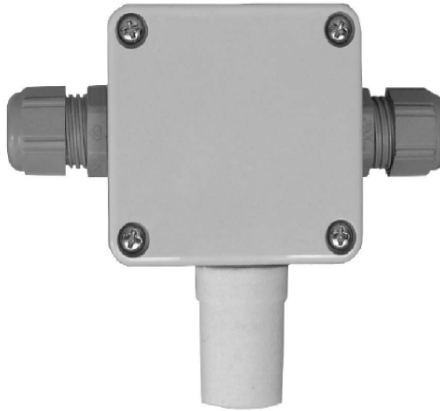

Read the user's manual carefully before starting to use the unit.  
Producer reserves the right to implement changes without prior notice.

## **CONTENTS**

<b>1. BASIC REQUIREMENTS AND USER SAFETY.....</b>	<b>3</b>
<b>2. GENERAL CHARACTERISTICS.....</b>	<b>4</b>
<b>3. TECHNICAL DATA.....</b>	<b>4</b>
<b>4. DEVICE INSTALLATION.....</b>	<b>5</b>
4.1. UNPACKING.....	5
4.2. ASSEMBLY.....	5
4.3. CONNECTION METHOD.....	6
4.4. MAINTENANCE.....	9
<b>5. PRINCIPLE OF OPERATION.....</b>	<b>9</b>
<b>6. THE MODBUS PROTOCOL HANDLING.....</b>	<b>10</b>
6.1. LIST OF REGISTERS.....	10
6.2. READING OF THE MEASUREMENT RESULT.....	11
6.3. TRANSMISSION ERRORS DESCRIPTION.....	11
6.4. EXAMPLES OF QUERY/ANSWER FRAMES.....	12
<b>7. FORCING OF 0xFF ADDRESS.....</b>	<b>14</b>

### **Explanation of symbols used in the manual:**



- This symbol denotes especially important guidelines concerning the installation and operation of the device. Not complying with the guidelines denoted by this symbol may cause an accident, damage or equipment destruction.

**IF THE DEVICE IS NOT USED ACCORDING TO THE MANUAL THE USER IS RESPONSIBLE FOR POSSIBLE DAMAGES.**



- This symbol denotes especially important characteristics of the unit.  
Read any information regarding this symbol carefully

## **1. BASIC REQUIREMENTS AND USER SAFETY**



- **The manufacturer is not responsible for any damages caused by inappropriate installation, not maintaining the proper technical condition and using the unit against its destination.**
- Installation should be conducted by qualified personnel . During installation all available safety requirements should be considered. The fitter is responsible for executing the installation according to this manual, local safety and EMC regulations.
- The unit must be properly set-up, according to the application. Incorrect configuration can cause defective operation, which can lead to unit damage or an accident.
- **If in the case of a defect of unit operation there is a risk of a serious threat to the safety of people or property additional, independent systems and solutions to prevent such a threat must be used.**
- **The unit uses dangerous voltage that can cause a lethal accident. The unit must be switched off and disconnected from the power supply prior to starting installation of troubleshooting (in the case of malfunction).**
- Neighbouring and mating equipment must meet the requirements of appropriate standards and regulations concerning safety and be equipped with adequate anti-overvoltage and anti-interference filters.
- **Do not attempt to disassemble, repair or modify the unit yourself. The unit has no user serviceable parts. Units, in which a defect was stated must be disconnected and submitted for repairs at an authorized service centre.**



- Do not use the unit in areas threatened with excessive shocks, vibrations, corrosive gasses and oils.
- Do not use the unit in explosion hazard areas.
- Do not use the unit in areas with significant temperature variations, exposed to icing.
- Do not use the unit in areas exposed to direct sunlight.
- Make sure that the ambient temperature (e.g. inside the control box) does not exceed the recommended values. In such cases forced cooling of the unit must be considered (e.g. by using a ventilator).



**The unit is designed for operation in an industrial environment and must not be used in a household environment or similar.**

## **2. GENERAL CHARACTERISTICS**

The temperature and humidity transducer is designed for multipoint temperature and humidity measurement system. In particular it is used for measuring conditions in rooms where food products are manufactured and stored. It is equipped with RS-485 / Modbus RTU communication interface. It has a small plastic casing.

## **3. TECHNICAL DATA**

Power supply voltage	typically 10 VDC (9 VDC - 12 VDC)
Current consumption	during operation - typically 4.2 mA during Modbus transmission - up to 60 mA
Temperature sensor	semiconductor integrated circuit
Measurement range	0°C up to 70°C
Measurement error	within the range -10°C up to +50°C: $\pm 0.5^\circ\text{C}$
Humidity sensor	
Measurement range	0% RH up to 100% RH
Accuracy	$\pm 2\%$ RH (at 25°C, no condensation)
Linearity	$\pm 0,5\%$ RH (typically)
Hysteresis	$\pm 1,2\%$ RH
Repeatability	$\pm 0,5\%$ RH
Stability	$\pm 1\%$ RH (at 50% RH, within 5 year)
Minimum response time	15 seconds
Number of modules in 1 network	maximum 127
Communication interface	RS 485, 8N1 / Modbus RTU
Baud rate	9600 bit/sec.
Data memory	non-volatile memory, EEPROM type
Protection level	IP 65 (ABS casing) IP 40 (sensor)
Housing type	wall mounted
Housing material	ABS
Housing dimensions (L x W x D)	
without glands	64 x 58 x 35 mm
with glands, and sensor protective cap	114 x 92 x 35 mm
Operating temperature	0°C up to 70°C
Storage temperature	-40°C up to +85°C
Altitude	up to 2000 meters above sea level
Fastening	to wall, 2 M3 bolts
Connection cable	4 conductors (2 supply conductors + 2 data transmission conductors)

Screws tightening max. torque	0,5 Nm
Max. connection leads diameter	2,5 mm <sup>2</sup>
EMC	PN-EN 61326:2003



**This is a class A unit. In housing or a similar area it can cause radio frequency interference. In such cases the user can be requested to use appropriate preventive measures.**



Detailed informations about installation of TRS system user can find in:  
**“User manual for Temperature and Humidity Recording System”**

## **4. DEVICE INSTALLATION**

The unit has been designed and manufactured in a way assuring a high level of user safety and resistance to interference occurring in a typical industrial environment. In order to take full advantage of these characteristics installation of the unit must be conducted correctly and according to the local regulations.



- Installation should be conducted by qualified personnel .
- Read the basic safety requirements on page 3 prior to starting the installation.
- All installation works must be conducted with a disconnected power supply.

### **4.1. UNPACKING**

After removing the unit from the protective packaging, check for transportation damage. Any transportation damage must be immediately reported to the carrier. Also, write down the unit serial number on the housing and report the damage to the manufacturer.

Attached with the unit please find:

- warranty,
- user's manual for **TRS-04a** unit (device)

### **4.2. ASSEMBLY**



- Disconnect the power supply prior to starting assembly.
- Check the correctness of the performed connections prior to switching the unit on.



To install the device prepare pinholes accordingly to Figure 4.1. Back side of the case (with mounting holes) should be mounted to a wall using screws.

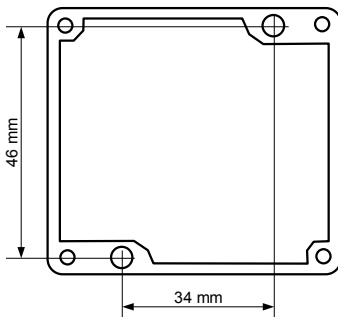

Figure 4.1. Distances between pinholes



1. **Do not exceed operating temperatures range 0°C do 70°C.**
2. The module should not be used in environment, where **vapour condensation occurs**. Condensation of vapours on the humidity sensor can cause temporal alarm (vapour condensation). Sensor will come back to correct measurement after all water will evaporated. Long time or often condensation of vapours can add constant (but removable) offset to sensor characteristic.
3. If humidity over 90%RH occurs for long time, sensor can (temporarily) change it's offset about 3%RH.
4. **Humidity sensor is light sensitive.** To preserve it's precision sensor must be protected of bright light (natural and artificial).Modules must not be mounted in direct sunlight, or artificial light sources (bulbs, burners).
5. **Avoid module of installation** near doors, windows (especially in rooms with higher temperature), air conditioners, ventilation, or assembly line where people work, machinery emitted vapours or high temperature, or needs periodic cleaning. To protect of installation changes (and it's costs), it is recommended to plan all places where sensors will be installed due to experiments made with portable temperature and humidity sensor.
6. It is important, to install measurement modules in place allowing **free air flow** around of sensors (best if flow is not stimulated mechanically). If module is mounted on absorbent or wet walls distance from sensor to wall should be higher than 7 cm. Remember, that stagnant air is perfect thermal insulator, so it can make significant differences between near placed sensors. To avoid of these situations, mechanically stimulated (but soft) air flow is recommended. Modules should be mounted in that way to direct sensors down.

### **4.3. CONNECTION METHOD**

#### **Caution**



- Installation should be conducted by qualified personnel . During installation all available safety requirements should be considered. The fitter is responsible for executing the installation according to this manual, local safety and EMC



regulations.

- Wiring must meet appropriate standards and local regulations and laws.
- Tighten the clamping screws. The recommended tightening torque is 0.5 Nm. Loose screws can cause fire or defective operation. Over tightening can lead to damaging the connections inside the units and breaking the thread.
- If the unit is equipped with housing, covers and sealing packing, protecting against water intrusion, pay special attention to their correct tightening or clamping. In the case of any doubt consider using additional preventive measures (covers, roofing, seals, etc.). Carelessly executed assembly can increase the risk of electric shock.

**Due to possible significant interference in industrial installations appropriate measures assuring correct operation of the unit must be applied. To avoid the unit of improper indications keep recommendations listed below.**

- Avoid common (parallel) leading of signal cables and transmission cables together with power supply cables and cables controlling induction loads (e.g. contactors). Such cables should cross at a right angle.
- Contactor coils and induction loads should be equipped with anti-interference protection systems, e.g. RC-type.
- In the case of magnetically induced interference the use of twisted couples of signal cables (so-called “spirals”) is recommended. The spiral (best if shielded) must be used with RS-485 serial transmission connections.
- In the case of interference from the power supply side the use of appropriate anti-interference filters is recommended. Bear in mind that the connection between the filter and the unit should be as short as possible and the metal housing of the filter must be connected to the earthing with largest possible surface. The cables connected to the filter output must not run in parallel with cables with interference (e.g. circuits controlling relays or contactors).

Connections of power supply voltage and measurement signals are executed using the screw connections inside of the unit's housing (Figure 4.2- 4.4).

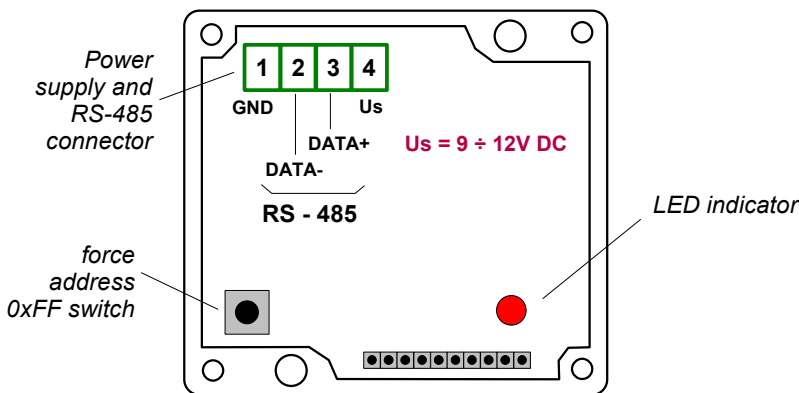

Figure 4.2. Location of elements inside the module case

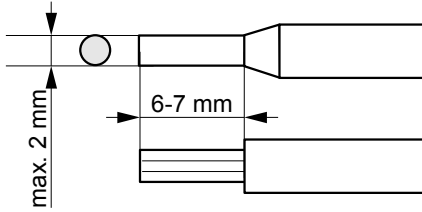
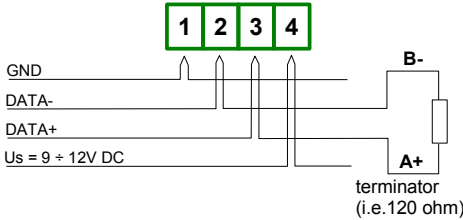

Figure 4.3. Method of cable insulation replacing and cable terminals



**Last module in the network must be terminated with 100÷150 Ohm resistor .**

Figure 4.4. Connection of the module to the network

An example of the transducers application is multipoint monitoring system (Figure 4.5). Control panel (i.e. SPA-99 made by SIMEX) is used as MASTER in MODBUS network, simultaneously it displays readed informations of all measurement points.

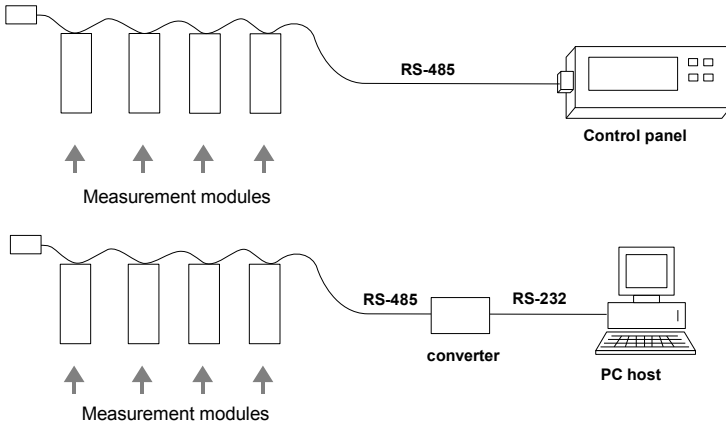

**RS-485 bus should be equipped with termination resistors (100-150 ohm) on both ends. The bus must not be ramified, and longer than 1 km.**

Figure 4.5. Example application of the transducers



## **4.4. MAINTENANCE**

The unit does not have any internal replaceable or adjustable components available to the user. Pay attention to the ambient temperature in the room where the unit is operating. Excessively high temperatures cause faster ageing of the internal components and shorten the fault-free time of unit operation.

In cases where the unit gets dirty do not clean with solvents. For cleaning use warm water with small amount of detergent or in the case of more significant contamination ethyl or isopropyl alcohol.



Using any other agents can cause permanent damage to the housing.



Product marked with this symbol should not be placed in municipal waste. Please check local regulations for disposal and electronic products.

## **5. PRINCIPLE OF OPERATION**

**TRS-04a** module is equipped with modern digital temperature and humidity converters. These IC has resolution of 12 bits. Converted measurement signals are transmitted to the microcontroller where they are computed and filtered according to given parameters. Implementation of thermal compensation of relative humidity algorithms allow to obtain higher precision of RH measurement. Measurement data can be readed from the module via RS-485 interface by any MASTER controller (i.e. Control panel or PC). In factoring process, the same address (0xFE) is written to every module. These addresses can be changed at any time using proper MODBUS commands, or can be forced to be reset to 0xFF value using module internal momentary switch (to enhance system installation process, see: **FORCING OF 0xFF ADDRESS**). All settings are stored in non-volatile EEPROM memory, and available under fixed register numbers.

LED indicator is installed in the module mainboard, it indicates following situations:

- normal operation mode - flashes every about 1 second.
- handmade forcing of address **0xFF** - permanent light

## 6. THE MODBUS PROTOCOL HANDLING

Transmission parameters: 1 start bit, 8 data bits, 1 stop bit, no parity control  
 Baud rate: 9600 bits/second  
 Transmission protocol: MODBUS RTU compatible

The device parameters and measurement result are available via RS-485 interface, as HOLDING-type registers of Modbus RTU protocol. The registers (or groups of the registers) can be read by 03h function, and wrote by 06h (single register only) accordingly to Modbus RTU specification. Maximum group size for 03h function can not exceeds 5 registers (for single frame).

The device interprets the broadcast messages, but then do not sends the answers.

### 6.1. LIST OF REGISTERS

Register	Write	Range	Register description
01h	No	-400 ÷ 850	Current temperature measurement value in 0.1 °C (U2 code, no decimal point included, e.g. value 350 means 35.0 °C)
02h	No	0h, 10h, 20h, 40h, 80h	The status of the current temperature measurement (see <b>TRANSMISSION ERRORS DESCRIPTION</b> )
03h	No	0 ÷ 1000	Current humidity measurement value in 0.1 % RH (U2 code, no decimal point included, e.g. value 600 means 60.0 % RH)
04h	No	00h, 41h, 81h	The status of the current humidity measurement (see <b>TRANSMISSION ERRORS DESCRIPTION</b> )
05h	No	1	Decimal point position of temperature, constant value: 1 - " 0.0 "
06h	No	1	Decimal point position of humidity, constant value: 1 - " 0.0 "
07h	Yes	0 ÷ 5	Temperature measurement filtering rate. Filtering rate 0 means no filtering, 1 – weakest filtering , 5 – strongest filtering
08h	Yes	0 ÷ 5	Humidity measurement filtering rate Filtering rate 0 means no filtering, 1 – weakest filtering , 5 – strongest filtering
05h ÷ 0Bh	-	see descr.	<b>Calibration registers - do not change</b> <b>WARNING: modification of these registers causes recalibration of module and inaccurate measurements !</b>
20h	Yes	0h ÷ FFh	Device address New modules has default address = 0xFE
21h	No	008Fh	Device identification code (ID)
0FFF0h 0FFF1h	No	see descr.	Unique serial number
0FFF2h	No	008Fh	Device identification code (ID)
0FFF3h	No	see descr.	Firmware version
0FFF4h	No	see descr.	Build number



- After writing to register no 20h the device responds with an “old” address in the message.
- If register 20h is being written it is possible to use BROADCAST frame (with address 00). This operation causes changing of addresses of all modules connected to the RS-485 network. Modules receive and interprets BROADCAST frames, but do not transmit answers.

## **6.2. READING OF THE MEASUREMENT RESULT**

Averaged (filtered) result of temperature measurements is available in holding register no. 01h, and averaged result of relative humidity measurement in register 03h. Reading of the result may be done using MODBUS RTU function 03h. If single holding register is being readed (01h or 03h), then module signalises any alarm situation by exception code (different than standard answer frame – see example 1). If group of holding registers (contain status register 02h or 04h) or only status register (02h or 04h) is being readed, then device transmits standard answer with current measurement status.

## **6.3. TRANSMISSION ERRORS DESCRIPTION**

If an error occurs while write or read of single register, then the device sends an error code according to Modbus RTU specifications (example message no 1).

Error codes:

- 00h** - measurement correct (this error code can be readed from status registers only),
- 01h** - illegal function (only functions 03h and 06h are available),
- 02h** - illegal register address,
- 03h** - illegal data value,
- 10h** - water inside module,
- 20h** - temperature sensor damaged,
- 40h** - exceed of lower border of temperature input range ( -40°C),
- 41h** - humidity sensor damaged,
- 80h** - exceed of upper border of temperature input range (85°C),
- 81h** - vapour condensation in humidity sensor.

10h code can appear only during reg. 01h or reg. 03h is reading by 03h function (read of a single register).

20h, 40h and 80h codes can appear only during reg. 01h is reading by 03h function (read of a single register).

41h and 81h codes can appear only during reg. 03h is reading by 03h function (read of a single register).



Error code can be a logical sum of two or more errors. Sensor failure usually do not breaks actualisation of measurement results, and current result can be readed using multi register mode ( in single register mode the modules send off the exception codes).

**6.4. EXAMPLES OF QUERY/ANSWER FRAMES**

Examples apply for device with address 1. All values are represent hexadecimal.

**Field description:**

<b>ADDR</b>	Device address on Modbus network
<b>FUNC</b>	Function code
<b>REG H,L</b>	Starting address (address of first register to read/write, Hi and Lo byte)
<b>COUNT H,L</b>	No. of registers to read/write (Hi and Lo byte)
<b>BYTE C</b>	Data byte count in answer frame
<b>DATA H,L</b>	Data byte (Hi and Lo byte)
<b>CRC L,H</b>	CRC error check (Hi and Lo byte)

**1. Read of the measurement value, the device address = 01h:**

ADDR	FUNC	REG H,L		COUNT H,L		CRC L,H	
01	03	00	01	00	01	D5	CA

a) The answer (we assume that input signal is not out of range):

ADDR	FUNC	BYTE C	DATA H,L		CRC L,H	
01	03	02	00	FF	F8	04

DATA H, L - measurement value = 255 (25,5°C), no decimal point. Decimal point position can be read from reg. 03h.

b) The answer (if an error occur):

ADDR	FUNC	ERROR	CRC L,H	
01	83	40	40	C0

ERROR - error code = 40h, bottom border of the measurement range is exceeded

**2. Read of ID code**

ADDR	FUNC	REG H,L		COUNT H,L		CRC L,H	
01	03	00	21	00	01	D4	00

The answer:

ADDR	FUNC	BYTE C	DATA H,L		CRC L,H	
01	03	02	00	8F	F9	E0

DATA - identification code (008Fh)

### 3. Change of the device address from 1 to 2 (write to reg. 20h)

ADDR	FUNC	REG H,L		DATA H,L		CRC L,H	
01	06	00	20	00	02	09	C1

DATA H - 0

DATA L - new device address (2)

The answer (the same as the message):

ADDR	FUNC	REG H,L		DATA H,L		CRC L,H	
01	06	00	20	00	02	09	C1

### 4. Read of the registers 1 and 2 in one message (example of reading a number of registries in one frame):

ADDR	FUNC	REG H,L		COUNT H,L		CRC L,H	
01	03	00	01	00	02	95	CB

COUNT L - the count of being read registers (max. 5)

a) The answer (we assume that input signal is not out of range):

ADDR	FUNC	BYTE C	DATA H1,L1		DATA H2,L2		CRC L,H	
01	03	04	00	C1	00	00	AB	CF

DATA H1, L1 - reg. 01h (193 - measurement value 19.3°C),

DATA H2, L2 - reg. 02h (0 - no errors),,

b) The answer (if an error occur):

ADDR	FUNC	BYTE C	DATA H1,L1		DATA H2,L2		CRC L,H	
01	03	04	00	C5	00	20	EB	D6

DATA H1, L1 - reg. 01h (197 - last correct measurement value 19.7°C),

DATA H2, L2 - reg. 02h (20h - temperature sensor failure)



**There is no full implementation of the Modbus Protocol in the device. The functions presented above are available only.**

## **7. FORCING OF 0xFF ADDRESS**

New devices has set to Modbus addresses 0xFE. To enhance system installation process special operation mode has been developed. It allows to force address 0xFF in single module using internal momentary switch mounted on module mainboard (Figure 4.2). Additionally this process forces baud rate to standard value 9600 bit/sec. To use this special mode MASTER controller must to search new devices – devices with address 0xFF. This process is implemented in Piggy Soft application as network configuration process.

To force address of device to value 0xFF, turn module power supply and wait until it's LED indicator flashes every 10 second. Next press internal switch button and hold it at least 4 seconds. While button is being pressed LED indicator is turned off until readdressing. After about 4 seconds LED indicator start to light permanently – it is signal that module address has been changed to 0xFF – then release switch. At this moment MASTER controller should find new device and readdress it (to address other than 0xFF). After remote readdressing LED indicator is being turned off, and starts to flashes again.

Change of the device address from FFh to 01h:

ADDR	FUNC	REG H,L		COUNT H,L		CRC L,H	
FF	06	00	20	00	01	5C	1E

The answer is the same as the message.

